

2712425

Page 1 of 75 12/14/2020 11:39:04 AM Fee: \$525.00
Eric Semerad - Gallatin County, MT MISC

After recording return to:

Griffith & Cummings PC

P.O. Box 160748

Big Sky, Montana 59716

**DECLARATION
FOR THE
EDGE 7 CONDOMINIUMS**

TABLE OF CONTENTS

Article 1 - DEFINITIONS 7

 1.1 Act..... 7

 1.2 Articles 7

 1.3 Assessments 7

 1.4 Association..... 7

 1.5 Board..... 7

 1.6 Building..... 7

 1.7 Bylaws..... 7

 1.8 Common Elements..... 7

 1.9 Common Expenses 9

 1.10 Community Association..... 9

 1.11 Community Association Governing Documents 9

 1.12 Construction Activity 9

 1.13 Declaration..... 9

 1.14 Design Guidelines 9

 1.15 Driveway 9

 1.16 Eligible Holder..... 9

 1.17 Function 9

 1.18 Good Standing 10

 1.19 Governing Documents 10

 1.20 Insurance Trustee 10

 1.21 Limited Expenses..... 10

 1.22 Manager 10

 1.23 MCA 10

 1.24 Percentage of Interest..... 10

 1.25 Permitted Household Pets: 10

 1.26 Person..... 10

 1.27 Plans..... 10

 1.28 Project 10

 1.29 Property..... 10

 1.30 Public Record..... 10

 1.31 Reserve Assessments 10

 1.32 Roadway 11

 1.33 Rules and Regulations..... 11

 1.34 Site Plan 11

 1.35 Unit(s)..... 11

 1.36 Unit Designation 11

 1.37 Unit Owner or Owner 11

 1.38 Unit Ownership Act 11

 1.39 Zoning Regulation 11

Article 2 - REAL ESTATE..... 11

 2.1 Purpose..... 11

 2.2 Real Property and Certificate of Exemption 11

 2.3 Certificate of Subdivision Plat Approval 11

2.4	Project	12
2.5	Access to the Project.....	12
2.6	Site Plan	12
2.7	Buildings.....	12
2.8	Construction Materials.....	12
2.9	Floor Plans	12
2.10	Boundaries of Units	12
2.11	Condominium Unit	13
2.12	Ownership of Units.....	13
Article 3 - EASEMENTS.....		13
3.1	Easements for Encroachments.....	13
3.2	Common Element Easements	13
3.3	Easement for Utilities Within Units.....	14
3.4	Easements for Public Utilities.....	14
3.5	Grant of Easements by Association.....	15
3.6	Easements for Maintenance, Repair, and Replacement.....	15
3.7	Site Plan or Service Easements.....	15
3.8	Structural Easements and Interior Remodeling.....	15
3.9	Specific Written Easements.....	16
3.10	Right of Access to the Interior of Units.....	16
Article 4 - THE ASSOCIATION.....		16
4.1	Association.....	16
4.2	Board of Directors.....	16
4.3	Rights of Association.....	17
4.4	Association Responsibilities	19
Article 5 - MEMBERSHIP		21
5.1	Regular Membership; Appurtenant Rights.....	21
Article 6 - FINANCES.....		23
6.1	Budget.....	23
6.2	Assessments	24
Article 7 - USE RESTRICTIONS		29
7.1	Common Elements.....	29
7.2	Use	30
7.3	Alterations.....	30
7.4	Leasing.....	31
7.5	Restriction on Number of Occupants per Unit	33
7.6	Restriction on Number of Units Owned by One Owner.....	33
7.7	Home Occupation	33
7.8	Activities.....	34
7.9	Animals.....	34
7.10	Aesthetics.....	35
7.11	Trash	35
7.12	Advertising and Signage.....	35
7.13	Hot Tubs.....	36
7.14	Parking	36

7.15	Lights	36
7.16	Marijuana	36
7.17	Satellite Dishes/Antennas	36
7.18	Handicapped Rights	36
7.19	Water & Sewer System	37
Article 8 - INSURANCE		38
8.1	Association Policies	38
8.2	Coverage	38
8.3	Claims Against the Association's Insurance Policies	40
8.4	Premiums and Deductibles	40
8.5	Policy Requirements	40
8.6	Waiver of Subrogation and Endorsements	41
8.7	Insurance Trustee	42
8.8	Unit Owners' Insurance	42
8.9	Distribution of Proceeds	43
8.10	Board as Agent	44
8.11	Benefit to Mortgagees	44
8.12	Notice to Lienholder	44
8.13	Reconstruction	44
8.14	Condemnation	46
Article 9 - MORTGAGEE PROVISIONS		47
9.1	Notice of Action	47
Article 10 - REMOVAL, PARTITION, AND SUBDIVISION		47
10.1	Board Approval	47
10.2	Member Approval	48
10.3	Division of Units	48
10.4	Common Elements	48
10.5	Removal or Partition - Subdivision	48
Article 11 - DECLARANT'S RIGHTS		48
11.1	Changes to Project	48
11.2	Timeframe for Completion	49
11.3	Assessments	49
11.4	Assignment	49
Article 12 - ENFORCEMENT AND REMEDIES		49
12.1	Procedure	49
12.2	Discretion	50
12.3	Costs of Enforcement	50
12.4	Delegation	50
12.5	Remedies Cumulative	51
12.6	Joint and Several Liability	51
Article 13 - AMENDMENT		51
13.1	Amendment By Declarant	51
13.2	Amendment By Board	51
13.3	Amendment By Owners	52
13.4	Power of Attorney	52

13.5	Annexation.....	51
13.6	Withdrawal.....	52
13.7	Plat Amendment.....	52
13.8	Merger or Consolidation.....	53
13.9	Agreement Regarding Amendments.....	53
13.10	Recording of Amendment.....	53
Article 14	- ANNEXATION, WITHDRAWAL AND REPLATTING OF PROPERTY.....	53
14.1	Annexation without Approval of Membership.....	53
14.2	Annexation with Approval of Membership.....	54
14.3	Withdrawal of Property.....	54
14.4	Replatting.....	54
Article 15	- CERTAIN OTHER RESTRICTIONS AND RIGHTS RESERVED TO DEVELOPER.....	55
15.1	Fractional Ownership.....	55
15.2	Leasing.....	55
15.3	Other Rights.....	55
Article 16	- INTERPRETATION.....	55
16.1	Liberal Construction.....	55
16.2	Interpretation of Governing Documents.....	55
Article 17	- SEVERABILITY.....	56
Article 18	- MISCELLANEOUS.....	56
18.1	Benefit.....	56
18.2	Binding Effect.....	56
18.3	Service of Process.....	56
18.4	Notices.....	56
18.5	Sale Disclosures.....	56
18.6	Gender.....	56
18.7	Conflicts.....	56
EXHIBIT A-1	- LEGAL DESCRIPTION OF PROPERTY.....	57
EXHIBIT A-2	- GALLATIN COUNTY EXEMPTION CERTIFICATE.....	58
EXHIBIT B	- CERTIFICATE OF NAME.....	59
EXHIBIT C	- SITE PLAN.....	60
EXHIBIT D	- CONSTRUCTION MATERIALS.....	61
EXHIBIT E-1	-- CERTIFICATE OF FLOOR PLANS.....	62
EXHIBIT F	- UNIT DESIGNATION AND PERCENTAGE OF INTEREST.....	63
EXHIBIT G	-- FLOOR PLANS.....	64
EXHIBIT H	-- MUNICIPAL FACILITIES EXCLUSION.....	65

DECLARATION FOR THE EDGE 7 CONDOMINIUMS

RECITALS

The foregoing recitals are incorporated into this Declaration as if fully recited herein.

This DECLARATION is hereby made and entered in this _____ day of _____, 20__ by **DEHAAN CONSTRUCTION, INC.**, a Montana Corporation referred to herein as “Declarant(s),” whereby lands and property hereinafter described are submitted and subject to the Montana Unit Ownership Act pursuant to Chapter 23, Title 70, MCA 2003, as amended.

The property subject to this Declaration shall be known as the **EDGE 7 CONDOMINIUMS**. (hereinafter referred to as the “Condominium, Property or Project”). The Condominium is located at Big Sky, Gallatin County, Montana. The Declarant is declaring **3 Buildings totaling 7 Units**.

NOW, THEREFORE, Declarant hereby declares that the Project and the property in each subsequent phase to the extent it becomes developed as described herein shall be held, conveyed, mortgaged, encumbered, leased, rented, used, occupied, sold, and improved subject to the declarations, limitations, covenants, conditions, restrictions, and easements contained in this Declaration, all of which are imposed as equitable servitudes pursuant to a general plan for the development of the Project for the purpose of enhancing and protecting the value and attractiveness of the Project, and every part of it, in accordance with the plan for the improvements of the Project and its division into Condominiums. All of the limitations, covenants, conditions, restrictions and easements shall constitute covenants that run with the land and are binding upon, and inure to the benefit of, Declarant, the Association, and all parties having or acquiring any right, title, or interest in or to any part of the Project or the Property in the Project.

This Declaration shall apply to all the real property and improvements placed or constructed thereon, and shall be in existence in perpetuity unless amended or terminated by operation of law. In the event any provision of this Declaration is judged to be invalid or unenforceable, the remaining provisions shall remain in full force and effect.

Article 1 - DEFINITIONS

Unless the context expressly provides otherwise, the following definitions shall pertain throughout this Declaration and in the interpretation thereof:

- 1.1 Act: Act means the Montana Nonprofit Corporation Act, §35-2-113 *et seq.*, MCA, as amended.
- 1.2 Articles: means the Articles of Incorporation of the Association, as the same may be amended, restated or replaced from time to time.
- 1.3 Assessments: collectively refers to all assessments as set forth in Article 7 below.

- 1.4 Association: means all of the Unit Owners acting as a group and in accordance with duly adopted Bylaws and this Declaration, also referred to as Edge 7 Condominium Owner's Association, Inc. a Montana nonprofit corporation, and any successor thereto.
- 1.5 Board: means the Board of Directors of the Association as more particularly defined in the Bylaws.
- 1.6 Building: means a structure containing Units.
- 1.7 Bylaws: means the Bylaws of the Association recorded on the _____ day of _____, 20____, as Document No. _____, records of Gallatin County, Montana, as such may be amended, restated or replaced from time to time.
- 1.8 Common Elements: means both General Common Elements and Limited Common Elements. For the avoidance of doubt, the Common Elements do not include the Units or any portion thereof.
- (a) **General Common Elements:** means all those elements within the Project which are for the use of all Unit Owners and their guests and invitees (some may be designated as "GCE" on the floor plans or site plan). The Association may add or delete General Common Elements by amendments to this Declaration and/or by the method set forth in the Unit Ownership Act. The General Common Elements include, but are not limited to, the following to the extent not within a Unit and not otherwise designated as a Limited Common Element:
- (i) the land on which the Buildings are located, except any portion thereof included in a Unit or made a Limited Common Element by this Declaration or amendment hereto;
 - (ii) the foundations, columns, girders, beams, supports, main walls, roofs and other structural components of the Buildings stairs, entrances and exits of Buildings, and siding and other exterior surfaces of the Buildings;
 - (iii) the sidewalks, parking, right-of-way improvements, landscaping, paths and other improvements or fixtures on the Property;
 - (iv) installations of central services existing for common use of all Units within the Building such as power, light, gas, television, telephone, sewer, and other utilities and connections to the extent serving all Units.
 - (v) public utility lines, water, sewer, electrical, gas, telephone and television lines, and similar infrastructure and facilities to the extent serving all Units or all Units within a Building, except those utility lines that are required pursuant to separate agreement to be maintained by the public utility;
 - (vi) the tanks, pumps, motors, fans, compressors, ducts and in general all

apparatus and installations existing for common use of all Units or of all Units within a Building;

- (vii) any facilities and improvements constructed on the Property for operation and maintenance of the Project or use by all Unit Owners; and
- (viii) landscaping, landscape and development lighting, security lighting, Project signage and signage lighting (if installed), other materials and improvements separate from and outside of the Units, and other elements necessary for or convenient to the safety, maintenance and existence of the Project.

(b) **Limited Common Elements:** means those Common Elements within the Project designated in this Declaration, site plan, or floor plans (some may be designated as "LCE" on the floor plans or site plan) or by agreement of the Unit Owners which are reserved for the use of a certain Unit or number of Units to the exclusion of the other Units. Specifically, as to any given Unit, Limited Common Elements shall include, but not be limited to, the following common elements which are outside the boundaries of the Unit and which are appurtenant to, affixed to or provide service or access to the Unit:

- (i) Driveways, stoops, decks, porches, terraces and patios;
- (ii) any other improvement, facility or item described in the definition of General Common Elements to the extent the Board, reasonably determines that such improvement, facility or item should equitably be treated a Limited Common Element for purposes of this Declaration.

1.9 **Common Expenses:** means expenses of administration, maintenance, repair or replacement of General Common Elements, expenses of administration, maintenance, repair or replacement of those Limited Common Elements that the Board votes to treat as General Common Elements, and all other expenses agreed upon by the Association of all Owners, and expenses declared common by the Unit Ownership Act. Such expenses shall include dues payable to the Association, and any reserve established by the Board to the extent relating to the General Common Elements, the Limited Common Elements for which the Association is responsible.

1.10 **Governing Documents:** means collectively the Articles of Incorporation, Declaration, Bylaws, and Rules and Regulations of Edge 7 Condominiums, as the same may be amended, restated or replaced from time to time.

1.11 **Construction Activity:** means any site preparation, landscaping, sign erection, construction, reconstruction, change, modification, alteration, enlargement or material maintenance of any improvements or real property, or any physical changes in the use of any Unit or other property or building or structure thereon, interior or exterior.

- 1.12 Declarant: means Dehaan Construction Inc.
- 1.13 Declaration: given in the first paragraph hereof.
- 1.14 Design Guidelines: means any Rules and Regulations adopted by the Board for the regulation and management of the Property or any portion thereof.
- 1.15 Driveway: means, with respect to each Building, those Limited Common Elements used for ingress and egress between a Roadway and the Building serving one or more Units.
- 1.16 Eligible Holder: has the meaning given in Article 9 - Mortgage Provisions.
- 1.17 Function: means any activity, function or service listed in this Declaration which is required to be or may be undertaken or performed by the Association as well as any activity, function or service otherwise undertaken or performed by the Association.
- 1.18 Good Standing: means that a Member is current on the payment of such Member's Assessments, is not deemed by the Board to be in violation of the Governing Documents and is current on any other payments deemed by the Board to be due and owing to the Association.
- 1.19 Governing Documents: means this Declaration, the Articles, the Bylaws, any Rules and Regulations and any and all other documents necessary for the formation of the Project, including, but not limited to, any surveys, plats, or site plans as the same may be amended, restated or replaced from time to time.
- 1.20 Insurance Trustee: has the meaning given in Section 8.7.
- 1.21 Limited Expenses: means the expenses attributable to the construction, administration, operation, maintenance, repair and replacement of Limited Common Elements, including any expenses incurred by the Association, and are expenses only for owners of units within the respective building for which the expenses are accrued, unless otherwise determined by the Board.
- 1.22 Manager: means the Board, a manager, a management corporation or any other person or group of persons retained or appointed by the Board, or by the Association, for the purpose of conducting the day-to-day operations of the Project.
- 1.23 MCA: means the Montana Code Annotated 2019 and any subsequent amendments.
- 1.24 Percentage of Interest: means each Unit Owner's undivided interest in the Common Elements and such Unit Owner's pro rata liability to the Association. The Percentage of Interest with respect to each Unit is specified on **Exhibit F** attached hereto.
- 1.25 Permitted Household Pets: has the meaning given in Section 7.9.
- 1.26 Person: means any natural person, corporation, partnership, limited liability company,

association, trust, or any other legal entity.

- 1.27 Plans: has the meaning given in Section 2.9.
- 1.28 Project: means the Property and all buildings, improvements and structures thereon and all easements, rights and appurtenances belonging thereto, which are herewith submitted to the Unit Ownership Act.
- 1.29 Property: means the real property located in Gallatin County, Montana and described on **Exhibit A** attached hereto, along with any property subsequently annexed or otherwise subjected to this Declaration.
- 1.30 Public Record: means the office of the Clerk and Recorder of Gallatin County where land records are recorded or filed.
- 1.31 Reserve Assessments: has the meaning given in Section 6.2(a)(ii).
- 1.32 Roadway: means a street or roadway (but excluding driveways) within the Property or a street or roadway providing primary or secondary access to the Property.
- 1.33 Rules and Regulations: means the specific rules, regulations and policies that may be adopted by the Board from time to time for governance and management of the Project or any portion thereof, as the same may be amended from time to time.
- 1.34 Site Plan: has the meaning given in Section 2.6.
- 1.35 Storage Units: means the general common element storage facilities outside of the Buildings that may be used as the Board determines in its Rules and Regulations.
- 1.36 Unit(s): means the separate condominium units of the Project that are built each of which is a parcel of property including and containing one or more rooms, intended for independent residential use, and with a direct exit leading to a public street or to Common Elements leading to a public street whether directly or indirectly by way of an easement or private street or way connecting to a public street. In this Declaration such Units refer to those Units which are designated on **Exhibit F**.
- 1.37 Unit Designation: means the combination of letters, numbers and words which identify the designated Units.
- 1.38 Unit Owner or Owner: means the person owning a Unit in fee simple absolute individually or as co-owner in any real estate tenancy relationship recognized under the laws of the State of Montana. Each Unit has only one owner for any voting purposes described herein.
- 1.39 Unit Ownership Act: means and refers to the Montana Unit Ownership Act, Section 70-23-101, *et seq.*, MCA (2019), as amended.
- 1.40 Zoning Regulation: means the regulations adopted by the City of Belgrade, Montana.

Article 2 - REAL ESTATE

- 2.1 **Purpose.** The purpose of this Declaration is to divide the Property into Units by submitting the Property and those improvements that exist and to be constructed on the Property to the condominium form of ownership and use in the manner provided by the Unit Ownership Act.
- 2.2 **Real Property and Certificate of Exemption.** The Property which is by this Declaration submitted and subject to the Unit Ownership Act is legally described in **Exhibit A-1**. The division of property is exempt from subdivision review as evidenced by the Certificate of Exemption from Subdivision Review attached as **Exhibit A-2**.
- 2.3 **Municipal Facilities Exclusion.** This Project has received a Municipal Facilities Exclusion for the real property for use of three (3) Buildings and seven (7) units as certified pursuant to MCA 76-4-125: (1) A subdivision excluded from the provisions of chapter 3 must be submitted for review according to the provisions of this part, except that the following divisions or parcels, unless the exclusions are used to evade the provisions of this part, are not subject to review (d) as certified pursuant to 76-4-127: (i) new divisions subject to review under the Montana Subdivision and Platting Act; (ii) divisions or previously divided parcels recorded with sanitary restrictions; or (iii) divisions or parcels of land that are exempt from the Montana Subdivision and Platting Act review under 76-3-203 or 76-3-207(1)(a), (1)(b), (1)(d), (1)(e), or (1)(f). The Municipal Facilities Exclusion is attached as **Exhibit H**.
- 2.4 **Project.** The Project shall be known by the name Edge 7 Condominiums. The Certificate of Name is attached hereto as **Exhibit B**. The Project is established in accordance with the Unit Ownership Act.
- 2.5 **Access to the Project.** Access to the Project from Oregon Street and Minnesota Street, and are collectively referred to as “Common Roads.” Unit Owners, by purchasing and owning Units within the Project, agree that they will waive their right to protest the creation of a special improvement district (SID) for the maintenance of the Common Roads.
- 2.6 **Site Plan.** The site plan of the Project showing the Buildings and Units, as well as, the dimensions and the designation of each Unit in relation to the Property (“Site Plan”) is attached hereto as **Exhibit C**.
- 2.7 **Buildings.** The Units comprising the condominium will be contained in a total of three (3) buildings, as specified in **Exhibit F**.
- 2.8 **Construction Materials.** The principal materials of construction of the Buildings are described on **Exhibit D** attached hereto.
- 2.9 **Floor Plans.** The floor plans showing the layout of each Unit, the area of each, the dimensions and the designation of each Unit and the location of each Unit in the Building,

the elevations of the Building and showing the common areas or Limited Common Elements contained within or attached to the Building and the respective certificates of floor plans are attached hereto as **Exhibit G.**

2.10 **Boundaries of Units.**

A. Unit: Each Unit shall be bounded by the interior surfaces of its perimeter walls, floors, suspended ceilings, and trim. A Unit shall include all lath, furring, wallboard, plasterboard, plaster, paneling, tiles, paint, finished flooring, unfinished flooring of a garage, and any other materials constituting any part of its finished surfaces, including unit access door(s), so described. All other portions of the walls, floors, or ceilings shall be a part of the Common Elements. In addition, each Unit shall include the following: (a) all spaces, interior partitions, windows, window frames, interior doors, door frames, and all other fixtures and improvements within the boundaries of the Unit, and (b) all outlets of utility service lines, including, but not limited to, power, light, gas, hot and cold water, heating, refrigeration, air conditioning, and waste disposal within the boundaries of the Unit, but shall not include any part of such lines or ducts themselves. In interpreting deeds, mortgages, deeds of trust, and other instruments for any purpose whatsoever or in connection with any matter, the existing physical boundaries of the Unit or of a Unit reconstructed in substantial accordance with the original plans hereof shall be conclusively presumed to be the boundaries regardless of settling, rising, or lateral movement of the Building and regardless of variances between boundaries as shown on the plat and those of the actual Building or Buildings.

B. **Perimetrical Boundaries of the Units.** The perimetrical boundaries of the Units shall be the following boundaries extended to an intersection with the upper and lower boundaries:

(a) **Exterior Building Walls.** The plane formed by the centerline of the exterior walls of the buildings except that such boundary shall be extended so as to include within it all windows in the Unit.

(b) **Interior Building Walls.** The Vertical planes of the centerline of the exterior walls between the Units extended to an intersection with the other perimetrical boundaries.

2.11 **Condominium Unit.** Each Unit, together with the appurtenant undivided interest in the Common Elements of the Project shall together comprise one Unit, shall be inseparable, and may be conveyed, leased, rented devised or encumbered as a fee simple interest in a parcel of real property. Included in all Units, as a part of each Unit, are the garages appurtenant to such Unit.

2.12 **Ownership of Units.** Each Owner shall be entitled to the exclusive ownership, use and possessions of his Unit and the percentage of the undivided interest of each Owner in the

Common Elements as set forth in **Exhibit F**. Such percentage represents the Owner's ownership interest in the general common elements, and Owner's liability for common expenses, and the voting interest of the Owner or Owners in all matters concerning the Association of Owners.

Article 3 - EASEMENTS

- 3.1 **Easements for Encroachments.** Easements for Encroachments. If any portion of the General Common Elements or Limited Common Elements encroaches upon a Unit or Units, a valid easement for the encroachment and for the maintenance of the same, so long as it stands, shall and does exist. If any portion of a Unit encroaches upon the General Common Elements or Limited Common Elements, or upon an adjoining Unit or Units, a valid easement for the encroachment and for the maintenance of the same, so long as it stands, shall and does exist. Such encroachments and easements shall not be considered or determined to be encumbrances either on the General Common Elements, the Limited Common Elements, or on the Units for the purpose of marketability of title. In the event a Building or any portion thereof is destroyed and then rebuilt, the Owners agree that minor encroachments of parts of the General Common Elements or Limited Common Elements because of such construction shall be permitted and that an easement for such encroachment and the maintenance and repair of the same shall and does exist.
- 3.2 **Common Element Easements.** A perpetual, nonexclusive easement and right of ingress and egress and support through the General Common Elements is appurtenant to each Unit for the benefit of each Owner and all the General Common Elements are subject to such rights. Every Owner shall have the right to use and enjoy the Limited Common Elements appurtenant to such Owner's Unit. The foregoing easements and rights are subject to the limitations and restrictions set forth in this Declaration and the other Governing Documents.
- 3.3 **Easement for Utilities Within Units.** Each Unit may have its air space penetrated by electrical wires and lines, gas lines, wastewater lines and other utility and mechanical lines, pipes or equipment. These lines, where they serve only one Unit shall be appurtenant to such Unit, but where they serve more than one Unit shall be part of the Common Elements – either limited or general depending on how many Units are being served thereby. Such items shall be so installed and maintained so that they shall not unreasonably interfere with the use of the Unit by the Owners of the same. A non-exclusive easement shall exist through, over and across each Unit for the use, inspection, installation, maintenance, replacement and repair of such utility lines for the use of all of the Owners or the Owners being serviced by the air space being penetrated by such lines and/or equipment. After completion of construction of build out of a Unit an easement for ingress and egress for the purpose of such inspection, installation, maintenance, replacement or repair of such easement rights shall only be exercised under the direction and approval and with the authority of the Association and/or the Manager unless an emergency exists in which event any action may reasonably be taken which is justified under the circumstances to minimize

damage which could otherwise occur as a consequence of such emergency. There shall be easements to, through and over those portions of the land, structures, buildings, improvements and walls (including interior building walls) contained therein for the continuing maintenance and repair of all utilities in the Building. The foregoing easements are all permanently reserved to the Declarant, the Association and the Owners. In the event the Board or the Manager must enter or cause to have an agent enter a Unit for such reasons as listed above, other than emergency, The Board or Manager must provide at least one week notice to the Owner or the Owner's agent or lessee. Notice can be provided either in writing, facsimile, electronic mail, or posting. Upon entering the Unit, the Board member or Manager shall provide documentation of their entry through written notification left at the premises of the time, date and work done in the Unit.

- 3.4 **Easements for Public Utilities.** There are hereby reserved unto the Association, and its designees access and maintenance easements upon, across, over, and under all the General Common Elements (provided that such access may not be across, over or under any Building) to the extent reasonably necessary for the purpose of installing, replacing, repairing, and maintaining security and similar systems, roads, walkways, bicycle pathways, drainage systems, street lights, signage, wells, drainfields, and all utilities, including, but not limited to, water, sewer, meter boxes, telephone, gas, and electricity, and for the purpose of installing any of the foregoing within easements designated for such purposes on recorded plats of the Property. The Board specifically reserves unto itself the right to convey to the local water and sewer district, electric company, natural gas supplier, or communications systems supplier easements across the General Common Elements (provided that such easements may not be across, over or under any Building or other structures or buildings) for ingress, egress, installation, reading, replacing, repairing, and maintaining utility meters and boxes. The exercise of this easement shall not extend to permitting entry into any Unit, nor shall any utilities or improvements be installed or relocated on the Property, except as approved by the Board.

Should any entity furnishing a service covered by the general easement herein provided request a specific easement by separate recordable document, the Board shall have the right to grant such easement over any portion of the Property without conflicting with the terms hereof.

- 3.5 **Grant of Easements by Association.** The Board shall be empowered and obligated to grant such easements, licenses, rights-of-entry and rights-of-way over, under and across the Property for utility purposes, access purposes or other lawful purposes as may be necessary for the benefit of the Condominium. The Board shall also have the power to grant such easements through the General Common Elements for utilities that may serve less than all Units.
- 3.6 **Easements for Maintenance, Repair, and Replacement.** The Board, and all public or private utilities shall have such easements over, under, across and through the Property, including all Units and Common Elements, as may be necessary to fulfill any responsibilities of maintenance, repair, or replacements which they or any of them are required or permitted to perform under this Declaration or Bylaws of the Association or by

law. These easements include, without any implication of limitation, the right of the Association to obtain access at all times to meters, controls, valves, pipes, conduits, and other Common Elements located within or to which access may be gained through any Unit or to its appurtenant Limited Common Elements. In the event the Board and/or the Manager must enter or cause to have an agent enter a Unit for such reasons as listed above it shall be done in accordance with Section 3.10 below.

3.7 Site Plan or Service Easements.

- (a) The Project shall be subject to all easements as shown on the Site Plan and to any other easements of record or of use. In addition, the Project is subject to all easements created by this Declaration. Each Owner by accepting a deed to a Unit, agrees for themselves and their invitees and successors and assigns, to be subject to such easements and the Rules and Regulations from time to time in effect governing the use of such easement areas.
- (b) The Owners hereby grant a non-exclusive perpetual easement across and over the Project for ingress and egress to all police, sheriff, fire protection, ambulance and similar emergency agencies or persons, now or hereafter serving the Project, to enter the Project in the performance of their duties, subject, however, to limitations generally imposed by local, state and federal law.

3.8 Structural Easements and Interior Remodeling. Every portion of a Unit which contributes to the structural support of the Building, other Units or the Common Elements shall be burdened with an easement of structural support for the benefit of the Building, Common Elements and other Units. Each Owner shall have the exclusive right to paint, repair, tile wallpaper, panel, carpet, brick or otherwise maintain, refinish and decorate the inner surfaces of the walls, ceilings, floors, windows and doors bounding his own Unit, and the interior thereof, so long as such work does not affect the structural integrity of the building.

3.9 Specific Written Easements. The Association may, in its sole discretion without the necessity of consent by any interested party, prepare and record a subsequent instrument to specifically define by legal description the easements created by or in accordance with this Article. Nothing in this paragraph shall be construed to give Declarant the right to create easements not otherwise created by or in accordance with this Article. The easements provided for in this Article shall in no way adversely affect any other recorded easement on the Property.

3.10 Right of Access to the Interior of Units. The Association shall have the irrevocable right, to be exercised by the Board or the Manager, of access to each Unit from time to time during reasonable working hours as may be necessary for the maintenance, repair or replacement of any of the Limited Common Elements therein or accessible therefrom or for making emergency repairs therein necessary for the maintenance repair or replacement of any of the Limited Common Elements therein necessary to prevent damage to the General or Limited Common Elements or to any Unit. It shall be the responsibility of each

Owner to provide the Association or its Manager with means of access to their Unit.

- (a) Damage to the interior or any part of the Unit resulting from maintenance, repair emergency repair or replacement of any of the General or Limited Common Elements or as a result of an emergency repair within another Unit at the instance of the Association shall be designated a Common Expense by the Association and assessed in accordance with such designation.
- (b) In the event the Board or the Manager must enter or cause to have an agent enter a Unit for such reasons as listed above other than emergency must provide at least one week notice to the Owner or the Owner's agent or lessee. Notice can be provided either in writing, facsimile, electronic mail, or posting. Upon entering the Unit, the Board member or Manager shall provide documentation of their entry through written notification left at the premises of the time, date and work done in the Unit.

Article 4 - THE ASSOCIATION

4.1 **Association.** The Project is governed by Edge 7 Condominium Owner's Association, Inc. a non-profit corporation formed with the Montana Secretary of State, hereinafter referred to as the Association.

4.2 **Board of Directors.**

- (a) **Number and Qualifications.** The business and affairs of the Association shall be managed by a Board of not less than three (3) and not more than five (5) directors. Directors are required to be Members of the Association.
- (b) **Tenure.** There is no limit as to the number of consecutive terms that a director may be elected or appointed.
- (c) **Election of Directors.** Directors shall be elected as set forth in the Bylaws.

4.3 **Rights of Association.** The Association, by and through its duly elected Board of Directors, shall have and may exercise any right or privilege given to it expressly by the Governing Documents or reasonably implied from or reasonably necessary to effectuate any such right or privilege. Except as otherwise specifically provided in the Governing Documents or by law, all rights and powers of the Association may be exercised by the Board without a vote of the Members. The powers and rights of the Association include, but are not limited to, the right to:

- (a) adopt Bylaws for the governance of the Association;
- (b) make provisions for the general management, repairs and maintenance of the General Common Elements, Limited Common Elements, and any other provisions for the benefit of the Association. The Association in conformance with this

Declaration, has the right to treat Limited Common Elements as General Common Elements for the purpose of funding repairs and maintenance and the right to repair and maintain limited common elements;

- (c) enter into agreements with adjacent owners' associations and expend Association funds for the maintenance of Common Roads, snow removal, and the storage and removal of garbage;
- (d) express authority to review, accept, condition, modify or deny all plans for all Construction Activity on the Property;
- (e) adopt Design Guidelines and/or reasonable Rules and Regulations for the administration and procedures for carrying out its duties including but not limited to the authority to require reasonable fees and deposits to be paid to the Association;
- (f) make capital expenditures, incur liabilities, enter into contracts and agreements, and provide services and functions as are necessary to affect the business of the Association, including, but not limited to, hiring and discharging managing agents and other employees, agents, and independent contractors;
- (g) perform any function as set forth in this Declaration, including, without limitation, by, through or under contractual agreements, licenses, or other arrangements with any governmental, quasi-governmental, private entity or any non-profit organization, as may be necessary or desirable;
- (h) enter any Unit in accordance with this Declaration;
- (i) adopt and amend budgets for revenues, expenditures and reserves and levy and collect Assessments from Members;
- (j) pay the expenses of the Association, and provide for the use and disposition of any insurance proceeds in the event of loss or damage;
- (k) purchase insurance policies to protect the real and personal property of the Association, including the General Common Elements, against casualty or loss and to protect the Association, officers, directors, and Staff (when acting in their official capacity) from liability (the extent and specific nature of coverage shall be determined by the Board in accordance with this Declaration);
- (l) provide for the indemnification of the Association's officers and directors;
- (m) borrow funds in order to pay for any expenditure or outlay authorized by the Governing Documents, including, but not limited to, funds borrowed from Declarant or an affiliate thereof, and to execute all such instruments evidencing such indebtedness as may be necessary or advisable; and assign its right to future income, including, without limitation, the right to receive Assessments, as security for any borrowed funds; *provided, however*, that the Association shall not use in

excess of seventy-five percent (75%) of the Association's total reserve funds or pledge assets with a value in excess of seventy-five percent (75%) of the total value of all Association assets as collateral for any borrowed funds without the affirmative vote of a majority of the Members;

- (n) pay or cause to be paid all ad valorem real estate taxes, special improvement and other assessments (ordinary and extraordinary), ad valorem personal property taxes, and all other taxes, duties, charges, fees and payments, if any, required to be made to any governmental or quasi- governmental entity which shall be imposed, assessed or levied upon, or arise in connection with, the real or personal property owned by the Association;
- (o) obtain and pay for legal, accounting and other professional and expert services;
- (p) deal with agencies, officers, boards, commissions, departments, and other governmental bodies on a local, state and federal basis to carry out the powers, duties and responsibilities herein;
- (q) institute, defend or intervene in litigation, arbitration, mediation, or an administrative proceeding in its own name on behalf of itself on matters affecting the Property or take such action as it deems necessary to enforce the Governing Documents;
- (r) settle legal disputes/matters on behalf of the Association which includes the power to settle on terms that would constitute a variance of the Declaration if the Board believes it is reasonable to do so;
- (s) in its discretion, appoint Persons to generally supervise and control the business of the Association and delegate certain powers, duties and responsibilities to such Persons;
- (t) has the power to adopt, amend, enforce and repeal Rules and Regulations applicable that apply to the Project, Unit Owners and their guests and invitees. Such Rules and Regulations may govern use of the Common Elements and Units, the personal conduct of Unit Owners and their family members, guests and invitees, and may govern construction and design criteria and aesthetic standards so as to further the use, enjoyment and aesthetics of the Project for the Owners, including, but not limited to, Rules and Regulations: to **(i)** prevent or reduce fire hazard; **(ii)** prevent disorder and disturbances of the peace, including regulation of Construction Activity; **(iii)** regulate pedestrian and vehicular traffic; **(iv)** regulate household animals, the environment and environmental practices; **(v)** regulate signs; **(vi)** regulate any use of the General Common Elements to assure fullest enjoyment of use by the Persons entitled to enjoy and use the same; **(vii)** promote the general health, safety and welfare of persons within the Property; and **(viii)** protect and preserve property and property rights. Such Rules and Regulations may also establish enforcement mechanisms, including penalties and monetary fines for

violation thereof. Following adoption, amendment or repeal of any Rules and Regulations the Board shall provide Unit Owners with notice thereof. Copies of all such Rules and Regulations and amendments thereto in effect from time to time shall be furnished to Unit Owners upon request; and

- (u) exercise all the powers that may be exercised by the Association under the Act and/or the Unit Ownership Act.

4.4 **Association Responsibilities.** The Association, by and through its duly elected Board of Directors shall have the following responsibilities:

- (a) **Records.** The Association shall maintain its records in accordance with applicable law and the Bylaws.
- (b) **Maintenance of General Common Elements.** The Association shall maintain and keep in repair the General Common Elements of the Condominium.
- (c) **Maintenance of Limited Common Elements.** All fixtures, utility lines and equipment installed in the Unit commencing at a point where the utilities enter the Unit shall be maintained and kept in repair by the Owner thereof. The Association shall do no act or any work that will impair the structural soundness or integrity of the Building or impair any easement. Except as the Association may determine pursuant to Sections (i and ii) below, the Owners that benefit from the Limited Common Elements shall maintain and keep in repair the Limited Common Elements of the Condominium.
 - (i) **Ability of the Board to Treat Limited Common Elements as General Common Elements.** The Board may determine that it is in the best interests of the Association to treat any or all of the Limited Common Elements as a General Common Element. If the Board votes by a majority to treat any or all Limited Common Elements as General Common Elements, then the Board will maintain and keep in repair those Limited Common Elements chosen to be treated as General Common Elements and the cost will be pass onto the Owners as a whole pursuant to the Percentage of Interest.
 - (ii) **Ability of the Board to Repair and/or Maintain Limited Common Elements.** Each Owner shall also keep all Limited Common Elements appurtenant to his Unit in a clean and sanitary condition and in good repair. If the Owner(s) fail to maintain or repair the Limited Common Elements, then the Association has the right to maintain and/or repair the Limited Common Element. All costs of repairing Limited Common Elements on behalf of the Owners who benefit from the Limited Common Elements, including costs of notice and attorney's fees will be a Special Assessment against the Owner(s)' Unit(s).
- (d) The right of the Association to repair, alter, and remodel is coupled with the

obligation to replace any finishing or other materials removed with similar type or kinds of materials.

Article 5 - MEMBERSHIP

5.1 **Regular Membership; Appurtenant Rights.**

- (a) **Owners.** Each Owner shall automatically, upon becoming the Owner of a Unit, be a member of the Association and shall remain a member for the period of the Owner's ownership of the Unit. There shall be only one Membership attributable to fee simple ownership of a Unit.
- (b) **Memberships Appurtenant.** Membership in the Association shall be limited to Owners. A Person may hold more than one Membership in the Association.
 - (i) Each Membership and the benefits and burdens relating to that Membership shall be appurtenant to the fee simple title to the Unit held by an Owner. The Owner shall hold the Membership appurtenant to that Unit as set forth herein and title to and ownership of the Membership shall pass automatically with fee simple title of a Unit, no matter how such title or interest is acquired. Membership may not be transferred separately from the fee simple title of a Unit.
 - (ii) No such Person who is an Owner shall be entitled to opt out, resign, or withdraw from being a Member, regardless of whether any Person uses or does not use the Common Elements or is the beneficiary of any function of the Association. The obligations of each Owner under this Declaration are mandatory, including, but not limited to, the payment of ongoing Assessments, and all obligations of each Owner set forth herein, regardless of when specific obligations arise or become payable during the term of any Owner's ownership of a Unit are deemed to be an obligation incurred and a commitment made as of the date of such Person becoming an Owner.
- (c) **Evidence of Membership and Registration of Mailing Address.** Any Person, upon becoming a Member, shall furnish to the Association a copy of the instrument vesting that Person with the interest required to make such Person a Member. Each such Member at the same time shall give a single name and address to which notices to such Member may be sent, as well as an e-mail address and telephone number by which that Person can be contacted. In the event of any change in the facts reported in the original written notice, including, without limitation, any change of ownership, the Member shall give a new written notice to the Association containing all the information required to be contained in the original notice. As against any Member, and any Person claiming by, through, or under such Member, the Association may, but shall not be obligated to, for any and all purposes, rely on the information reflected in the most recent written notice furnished with respect to such Member. In no event will the Association have any

obligation to investigate the address or contact information of any Member.

- (d) **Joint Ownership; Joint and Several Liability.** If a Unit Owner's or other person's ownership interest in a Unit is held by more than one person or entity (in tenancy in common, as joint tenants, or otherwise), the membership in the Association appurtenant to such Unit shall be shared by all such persons or entities in the same proportionate interest and by the same type of ownership as the Unit is held, subject to reasonable Board regulation and restrictions on voting, notices, and assessment obligations as set forth in the Bylaws or otherwise. All such persons and entities shall be jointly and severally obligated to perform the responsibilities of the specific Unit Owner under the Governing Documents, including, without limitation, payment of assessments and other amounts owed pursuant to the Governing Documents. The membership rights of a Unit Owner that is not a natural person may be exercised by any officer, director, partner, trustee, member, manager, or other individual designated from time to time in a written instrument describing and certifying the authority of such person provided to the Secretary of the Association. In a multiple interest owner situation, if more than one person seeks to exercise the vote, the voting privilege shall be suspended. Neither the Association nor Declarant shall have any obligation to confirm, as among such multiple interest owners, which of the persons has the right to exercise a vote. In the case where a Unit Owner is not a natural person, or where there are multiple owners of a Unit, written notice shall be provided to the Secretary of the Association stating which person has authority to act on behalf of the Unit Owner and include that person's name, mailing and physical address, telephone number and e-mail address. The Association may rely on such notice until such notice is updated by a Unit Owner.
- (e) **Right to Examine Books.** Every Owner and Eligible Holder shall have the right to examine the books and records of the Association and of any Manager for the Project by giving a written notice requesting such examination. Upon receipt of such notice the party receiving the notice shall schedule a mutually agreeable date and time during normal business hours for the examination which date shall not be more than fifteen (15) days following the receipt of the notice requesting the examination.
- (f) **Voting Rights of Members.** On all matters to be decided by the Association, unless excluded by this Declaration, each Owner shall have a voting interest equal to his Percentage of Interest in the General Common Elements as set forth in this Declaration. When more than one person owns any Unit, all such persons shall be Members. The vote for such Unit shall be exercised as the Owners among themselves determine, but in no event shall more than the allocated Percentage of Interest vote be cast with respect to any Unit.
- (g) **Meetings.** Meetings of the Membership shall be conducted in accordance with the Bylaws.

(h) **Member Responsibilities.**

- (i) **Maintenance of Unit by Owners.** An Owner shall maintain and keep in repair the interior of his own Unit. All fixtures, utility lines and equipment installed in the Unit commencing at a point where the utilities enter the Unit shall be maintained and kept in repair by the Owner. An Owner shall do no act, nor any work that will impair the structural soundness or integrity of a Building or impair any easement. An Owner shall also keep all areas and Limited Common Elements appurtenant to his Unit in a neat, clean and sanitary condition. No acts of alteration, repairing or remodeling by the Owner shall impair in any way the structural integrity of Limited Common Elements or General Common Elements.
- (ii) **Rules and Regulations.** Each Member and their licensee and/or invitee is hereby deemed to have notice of all Rules and Regulations adopted by the Association, whether or not the same have been recorded, and shall be obligated to and shall comply with and abide by such Rules and Regulations, and pay such Default Assessments which shall be enforceable in accordance with this Declaration. Any current or potential Member, investor, lender or purchaser in relation to the Property may request that the Association provide a copy of the Rules and Regulations to such Member, potential Member, investor, lender or purchaser. Upon the new adoption or material amendment of Rules and Regulations, the Association shall provide all current Members affected by such Rules and Regulations with copies of such documents or notification of the adoption of such documents and notice as to where copies may be obtained. Copies of such documents may be made available at offices of the Association or its agents or on an electronic or otherwise generally accessible medium. Each Member is obligated to inform all licensees and invitees of the obligations and restrictions set forth in the Governing Documents and to cause such licensees and invitees to comply with such obligations and restrictions; *provided, however*, that failure to so inform any licensees or invitees shall not impair the enforceability of any Governing Document.
- (iii) **Notice of Sale of Unit.** Upon entering a contract for sale of a Unit, the Member owning such Unit shall, within a reasonable time thereafter, notify the Board in writing of the sale. Such notice shall include the name and phone number or email address of the purchaser and the proposed closing date.

Article 6 - FINANCES

6.1 **Budget.** The Association shall establish a budget in the following manner:

- (a) **Preparation.** At least sixty (60) days before the beginning of each fiscal year, the

Board shall prepare a budget covering the estimated Common Expenses during the coming year, including, without limitation, a capital contribution to establish a reserve fund in accordance with a budget separately prepared. The Board shall annually prepare the reserve budget which takes into account the number and nature of depreciable assets owned by the Association, the expected life of each asset, and their expected repair or replacement cost.

- (b) **Notices.** The Board shall send a copy of the preliminary annual budget and notice of the amount of the assessments for the upcoming year to be delivered to each Owner at least thirty (30) days prior to the beginning of the fiscal year for which it is to be effective.
- (c) **Approval.** The preliminary annual budget and assessment shall automatically become effective at the adjournment of the annual meeting unless disapproved at the annual meeting by at least fifty-one percent (51%) of the Owners in the Association.
- (d) **Failure to Approve Budget.** If the preliminary budget and assessment is disapproved or the Board fails for any reason to determine the budget for any year, then until such time as a budget is determined, the budget in effect for the immediately preceding year shall continue for the next year.

6.2 **Assessments.** The Association shall levy assessments upon the Owners in the following manner and for the following purposes:

- (a) **Types of Assessments.**
 - (i) **Annual Assessments.** The Board shall establish and levy “**Annual Assessments**” in the amount that the Board estimates will be sufficient to raise the funds needed to perform the duties of the Association during each fiscal year.
 - (ii) **Reserve Assessments.** The Board shall establish and levy annually “**Reserve Assessments**” in the amount that the Board estimates will be sufficient to raise the funds needed to build reserves to maintain and replace the Common Elements. This amount shall be at least 10% of the total yearly budget, unless a lower amount is deemed sufficient by the Board based upon an acceptable reserve study. The Board may levy Reserve Assessments against the Units that are specific to meet the needs of the respective unit types. By way of example but not limitation, the Board may levy Reserve Assessments and maintain a specific line item in the budget to reserve for the roofing needs of the Units as they were built at the same time with the same materials. Reserve Assessments may be collected for use by the Association for the repair and replacement of capital expenditures, including but not limited to: insurance deductible, roof, siding, equipment, infrastructure and other amenities related within

the Project.

- (iii) **Special Assessments.** The Board at any time may levy a “**Special Assessment**” in order to raise funds for unexpected operating or other costs, insufficient operating or reserve funds, or such other purposes as the Board in its discretion considers appropriate.
- (iv) **Specific Assessments.** The Board shall have the power to specifically assess those Units that receive benefits, items, or services that are specifically related to those Units that are not provided to all Units within the Project that are incurred for the benefit of those Owners for specific items or services relating to their specific Limited Common Elements, as determined by the Board in good faith. All such assessments shall be “**Specific Assessments.**”
- (v) **Default Assessments.** Notwithstanding anything to the contrary contained herein, if any cost or expense of the Association is caused by (a) the negligence or misconduct of an Owner or an Owner’s family member, employee, agent, licensee or invitee, or a violation of any covenant or condition of a Governing Document by an Owner or an Owner’s family member, employee, agent, licensee or invitee, the Association may, if the Board deems necessary or advisable, levy a default assessment against such Owner. The Association may also, in the discretion of the Board, levy a default assessment against any Unit to reimburse the Association for costs incurred in bringing the Unit into compliance with the provisions of the Governing Documents, provided the Association gives prior notice to the Owner and an opportunity to respond to the Board. Any such assessment levied by the Association pursuant to this section, and each fine, penalty, fee, or other charge imposed upon an Owner for the Owner or an Owner’s family member, employee, agent, licensee or invitee violation of any covenant or condition of any Governing Document, are each referred to herein as a “**Default Assessment.**”

(b) **Purpose.**

- (i) Assessments shall be made for the maintenance, repair, replacement, insurance, management, and administration of General Common Elements if any, utilities, reserves for contingent liabilities and other related items and assessments for the Owner’s percentage share of any assessment from the Community Association. Assessments for General Common Element Expenses shall be based upon and computed by using the percentage of interest that each Owner has in relation to the common elements.
- (ii) Assessments shall also be made for the maintenance, repair, and replacement of Limited Common Elements if any, such that the Owners are chargeable only for the expenses relating to Limited Common

Elements serving their respective Units in accordance with the percentage of the Unit or Units have in the Limited Common Element which serves the Units and for which the assessment is being made. If only one Unit is associated with the Limited Common Element, then the entire cost of such repair maintenance or replacement shall be borne by that Unit. The Board may choose to treat a Limited Common Element as a General Common Element for the purpose of this section if the Board determines it is in the best interests of the Owners to do so.

- (iii) Assessments may also be made for any purpose contemplated by this Declaration and for any purpose set out in the Unit Ownership Act.
 - (iv) The Reserve Assessment shall be assessed as the Board considers appropriate to adequately meet the costs of the future repair, replacement or additions to Common Element improvements and fixtures that the Association is obligated to maintain and repair. Reserves for General Common Elements shall be assessed according to the Unit's percentage interest. Reserves for Limited Common Elements shall be assessed to the Unit(s) to which they are appurtenant. The Board may choose to treat a Limited Common Element as a General Common Element if it is in the best interests of the Owners to do so.
 - (v) Damage to any part of a Unit resulting from maintenance, repair, emergency repair or replacement of any of the General Common Elements or Limited Common Elements or as a result of an emergency repair within another Unit at the instance of the Association (other than damage caused by a Unit Owner or a family member, guest or invitee thereof) shall be designated Common Expenses by the Association and assessed in accordance with such designation.
- (c) **Payment of Assessments.** All Assessments shall be due ten days (10) from the date of mailing notice of such Assessments to the Owners. Any Assessment may be payable in installments, monthly or quarterly, at the option of the Board. The amount of the General Common Expenses assessed against each Unit and the amount of Limited Expenses assessed against each Unit shall be the personal and individual debt of the Owner thereof. If the Owner is a corporation, limited liability company, limited partnership, trust or similar entity then the underlying shareholders, unitholders, beneficiaries, limited partners, etc. agreed that by purchasing a Unit that waive all protections given by their entity and agree that they are personally liable for any debt owed to the Association. (For example, if the entity is a corporation, the Association may automatically pierce the corporate veil to hold the shareholders personally liable for the debt). No Owner may exempt himself from liability for these contributions toward the Common Expenses by waiver of the use of enjoyment of any of the common elements or by abandonment or lease of his Unit.

- (i) Common Expenses of the Association shall be levied against the Units on a pro rata basis based upon Percentage of Interest.
- (ii) Limited Expenses shall be levied against Units as a Specific Assessment, against the Unit Owner(s) that benefit from the use of the Limited Common Element except in cases where the Board has determined the Limited Common Element should be treated as a Common Element.
- (iii) All monies owed the Association by an Owner, including but not limited to judgment awards and judgment interest and costs of collection are also Default Assessments against the Unit Owner(s)' Unit that run with the land and attach upon notice from the Association that the monies are due/or upon award by the Court.
- (d) **Owner Liability.** In a voluntary conveyance of a Unit, the grantee is jointly and severally liable with the grantor for all unpaid charges against the latter for grantee's proportionate share of the Common Expenses up to the time of the grant or conveyance, without prejudice to the grantee's right to recover from the grantor the amounts paid by the grantee therefore.
- (e) **Waiver of Homestead.** By purchasing a Unit a Unit Owner agrees that any filed Homestead Exemption does NOT apply to any amounts owed under the Governing Documents, including but not limited to Assessments and all court costs, monies, attorney's fees and judgment interest owed to the Association as a result of any case involving the Association where the Association is awarded such case, including the costs of collection.
- (f) **Verification of Assessments Due.** Upon written request, the Association or its Manager will furnish to a Member or such Member's title or mortgage company written verification of the amount of such Assessments owing and whether the Member has paid such Assessment. The Association or its agent may charge a reasonable fee for the verification of assessments due.
- (g) **Restrictions on Assessments and Expenditures.** The Board may not impose an Annual Assessment on any Unit which is more than twenty percent (20%) greater than the Annual Assessment for the immediate preceding fiscal year, or levy Special Assessments which in the aggregate exceed twenty percent (20%) of the total budget of the Association for that fiscal year, without the vote and/or written consent of a majority of the aggregate voting interests of the Association. In addition, with the exception of expenditures required for emergency situations or expenditures that were included in the Association's budget for the fiscal year, no single expenditure or debt in excess of Twenty Thousand Dollars and Zero Cents (\$20,000.00.00) may be made or incurred by the Association in a fiscal year without the prior approval of the Board. The limitation on single expenditures may be modified by the Board without amendment to this Declaration.

- (h) **Unpaid Assessment.** All assessments that are not paid within thirty (30) days from the date they are due and payable become delinquent and are subject to interest charges to be determined by the Board and penalty charges equal to ten percent (10%) of the delinquent Assessment. The Board or Manager shall have the responsibility of taking prompt action to collect any unpaid Assessments that become delinquent, such action shall be any remedy available at law to the Association including but not limited to the rights set forth in this Declaration. However, as the obligation to pay Assessments is a covenant that runs with the land, the Association is not required to lien the Unit in order to recover past due amount(s), regardless of any sale of the Unit. Suit to recover a money judgment for unpaid Common Expenses and Limited Expenses may be maintainable without foreclosing or waiving any lien securing the same.

- (i) **Unpaid Assessments - Mortgagee.** Where a lienholder or other purchaser of a Unit obtains title to the Unit as a result of foreclosure of the first mortgage or trust indenture, such acquirer of title, his successors and assigns, shall not be liable for the share of assessments by the Association chargeable to such Unit which became due prior to the acquisition of title to such Unit by such acquirer. Such unpaid assessments shall be deemed to be Common Expenses collectable from all of the Units including such acquirer and such acquirer's successors and assigns.

- (j) **Enforcement For Failure to Pay Assessments.**
 - (i) **Liens.** All sums assessed but unpaid for the share of General Common Expenses and Limited Common Expenses chargeable to any Unit shall constitute an automatic lien on such Unit superior to all other liens and encumbrances, except only for tax and special assessment liens on the Unit in favor of any assessing authority, and all sums unpaid on a first mortgage or a first trust indenture of record, including all unpaid obligatory sums as may be provided by such encumbrance. Since the obligation to pay Assessments is a covenant that runs with the land, the Association is not required to lien the Unit in order to recover past due amount(s), regardless of any sale of the Unit. Should the Association desire, the Manager or Board's agent may prepare a written notice of lien assessment setting forth the amount of such unpaid indebtedness, the amount of accrued interest and penalties thereon, the name of the Owner of the Unit and the legal description of the Unit. Such notice may be signed and verified by one of the officers of the Association or by the Manager, or his authorized agent, and it may be recorded in the office of the Clerk and Recorder of Park County, Montana. Regardless of the filing date, the assessment lien attaches from the date the Assessment is first levied.

 - (ii) **Foreclosure and Bidding at Foreclosure.** Such lien may be enforced by the foreclosure of the defaulting Owner's Unit by the Association in the manner provided in the Act and as provide by the foreclosure of a mortgage on real property upon the recording of a notice of a claim thereof.

In any such foreclosure, the Owner shall be required to pay a reasonable rental for the Unit and the Plaintiff in such foreclosure actions shall be entitled to the appointment of a receiver to collect the same. Suit to recover a money judgment for unpaid Common Expenses shall be maintainable without foreclosure or waiving the lien securing the same. In any such proceeding the Owner may be required to pay the costs, expenses and attorney's fees incurred in filing a lien, and in the event of foreclosure proceedings, additional costs, expenses and attorney's fees incurred. The Board on behalf of the other Owners shall have the power to bid on the Unit at a foreclosure or other legal sale and to acquire and hold, lease, mortgage and convey or otherwise deal with the same. Any lienholder holding a lien on a Unit may pay, but shall not be required to pay, any unpaid general Common Expenses, or Limited Common Expenses payable with respect to any such Unit, and upon such payment, such lienholder shall have a lien on said Unit for the amounts paid of the same rank as the lien of his encumbrance without the necessity of having to file notice or claim of such lien.

Article 7 - USE RESTRICTIONS

All of the Units and the Common Elements shall be held, used and enjoyed subject to the Governing Documents, Zoning Regulations and the following limitations and restrictions:

7.1 **Common Elements.** Each Owner may use the General Common Elements and Limited Common Elements in accordance with this Declaration and the other Governing Documents for the purposes for which they are intended, so long as they do not hinder or encroach upon the lawful rights of other Unit Owners.

- (a) Except as otherwise set forth in this Declaration, there shall be no obstruction of the Common Elements nor shall anything be stored in or on the Common Elements without the prior consent of the Association. "Obstruction of the Common Elements" includes, but is not limited to, parking and storage of any vehicle, machinery, equipment, campers, trailers, boats, motor homes, recreational vehicles, or other personal property upon landscaped, paved and undeveloped portions of the Property. Any item identified by the Association as an obstruction of Common Elements may removed from the Property and disposed of the without liability to the Owners at the Owner's expense. The Board shall adopt Rules and Regulations governing this removal process. Each Owner shall be obligated to maintain and keep in good order and repair the interior of their Unit. No Unit or parking space (designated or common) shall be used for the storage of any inoperable vehicle, machinery or equipment, or other personal property of any quality in excess of the immediate needs and personal use of the Owner of a Unit or the occupants thereof. No recreational equipment or vehicles, including, but not limited to, campers, trailers, motorboats, drift boats, rafts, motor homes, snowmobiles and four wheelers

shall be kept on the Property for any duration of time.

- (b) Nothing shall be done in in, on or to the Common Elements which will impair the structural integrity of a Building or any Common Element or which would structurally change a Building or Common Element, except as is otherwise provided herein and in accordance with the Governing Documents.
- (c) Except as otherwise set forth in this Declaration or as approved by the Board or Declarant, nothing shall be altered or constructed in or removed from the Common Elements.

7.2 **Use.** The Units shall be used only for residential occupancy by Unit Owners, their families, and their guests and invitees, consistent with the restrictions contained herein and in the other Governing Documents and may not be used for any other purposes whatsoever.

7.3 **Alterations.**

- (a) **Exterior Alterations.** No Owner may change, alter or remodel the exterior of his Unit without the prior written approval of the Board.
- (b) **Interior Alterations and Modifications by Owner.** The interior plan of the Unit may be changed by its Owner, with the exception of the bearing walls which may not be moved, although no Units may be subdivided. Prior to such alterations, however, the Owner(s) of the unit to be altered shall give at least thirty (30) days notice to the Association of the intent to alter the Unit, together with all necessary information to conclusively establish that such alteration shall not impair the structural integrity or any of the Common Elements of the Building. No change in the boundaries of the Units shall encroach upon the boundaries of the Common Elements, except by amendment to this Declaration. Altered boundary walls must be equal to the quality of design and construction of the existing boundary walls. A change in the boundaries between Units shall be set forth in an amendment to this Declaration. In addition, to comply with the provisions of **Article 13** below, such an amendment must further set forth and contain plans for the Units concerned, showing the Units after the change in boundaries, which shall be attached to the amendment as exhibits. Such an amendment shall be signed and acknowledged by the Owners of the Units concerned; as well as those Owners with an interest in any common elements affected, together with words of conveyance in the amendment conveying interests acquired in the Units or Common Elements by such change. The amendment shall also be approved by the Board and signed and acknowledged by all lienholders and mortgagees of the Units concerned.
- (c) **Change in Unit Boundaries.** No change in the boundaries of existing Units shall encroach upon the boundaries of the Common Elements or other Units except by amendment to this Declaration. Any such change will be set forth in an amendment showing the revised plans of the Unit(s) which amendment shall be approved, signed and acknowledged by the Association, the Owner(s) of the applicable

Unit(s) and all lien holders and mortgagees of the Units concerned, to the extent required by the Unit Ownership Act. Boundary walls must be equal in quality of design and construction to the existing boundary walls.

- (d) **Load Bearing Walls.** Notwithstanding any rights to remodel the Units, load bearing walls may not be moved or structurally altered.
- (e) **Liens for Alterations or Modifications.** Labor performed and materials furnished and incorporated into a Unit with the consent of or at the request of the Unit Owner, or such Unit Owner's agent, contractor or subcontractor, may be the basis for the filing of a lien against the Unit or the Unit Owner consenting to or requesting the same. Each Unit Owner and any other person having an ownership interest in a Unit shall indemnify and hold harmless each of the other Owners against any lien against the Unit or against the General Common Elements or Limited Common Elements for construction performed or for labor, materials, services or other products incorporated in the applicable Unit at such Owner's or such other person's request.

7.4 **Leasing.**

- (a) The leasing of Condominium Units is subject to the Montana Human Rights Act and all the provisions of the applicable Belgrade City Code(s). Units may be leased according to the conditions set forth in this Article.
- (b) "Lease" is defined as allowing a person(s) to occupy all or any part of a Unit for a monetary consideration or its equivalent. Nothing herein shall preclude a Unit Owner from retaining a live-in health care provider.
- (c) The Association may establish a maximum number of Leased Units within the Project; however, the percentage of rental Units may not exceed the current FHA Condominium Project owner-occupancy requirement. The Leased Units shall be determined on a first come, first served basis. In order to Lease a Unit, the Owner must request in writing to the Board of Directors that the Unit become a Leased Unit. If there are less than the approved number of the Units Leased at the time of the request, the Board shall grant the request. The Owner will have ninety (90) days from the time of approval to secure a valid, signed Lease or, if a vacation rental, show that the Unit is listed for rent as a vacation rental. The Owner shall provide the Board the information required in the Rules and Regulations made regarding Leasing. The Board will keep a list of which Units are Leased. Should an Owner Lease a Unit without obtaining permission of the Board, the Board shall have the power to enforce this provision with an action for possession of the Unit (i.e. eviction) should the Board deem such an action necessary.
- (d) The Board of Directors may consider requests from owners to exceed the limit set by the Board for special circumstances the Board of Directors deems reasonable. If such a request is granted, it shall be for a period not to exceed one year, provided,

however the Board of Directors may consider requests to extend beyond the one-year period and shall either grant or deny such request within forty-five (45) days of receiving a written request for extension.

- (e) When the maximum number of the Units are Leased, Owners of Units desiring to offer other Units for Lease may make a request to the Board of Directors to be placed on the waiting list. A waiting list of Unit Owner(s) wanting to lease their Unit shall be established and Units shall be placed on the waiting list on a first-come, first-serve basis. The Owner of first Unit on the top of the waiting list shall be notified in writing when the number of leased Units is less than the maximum number of the Units. The Owner will have ninety (90) days from the date of notice to secure a valid, signed Lease. If at the expiration of this ninety (90) day period and a Lease has not been provided to the Board of Directors, the next Unit in line on the waiting list shall be granted pending permission by the Board of Directors to lease their Unit. Unit Owners are to be given the same procedures established until the current policy for Leased Units has been reached.
- (f) Units Leased at the time of the effective date of this policy will be allowed to remain in Leased status until the property is re-occupied by an Owner. At that time, the Unit may be Leased only in accordance with this Leasing policy. New Owner(s) of formerly Leased Units and/or Owners who re-occupy a formerly Leased Unit will not receive priority over other Owners on the waiting list.
- (g) Lessors must, at Lessor's expense, provide Lessees with copies of the Covenants, Bylaws, and Rules and Regulations. Leases must specify that the Lessees/occupants must comply with all provisions of these three documents.
- (h) Occupancy shall be limited to those individuals named on the lease, except for bona fide short-term (less than two weeks) guests of the Owners. Guests are people who are visiting the Owners for no compensation.
- (i) The Owner's Association is not responsible for Leases negotiated by any of its members, nor is it responsible for its members' advertisements seeking Lessees. It is the responsibility of individual owner/lessors to comply with local, state, and federal laws relative to the leasing process.
- (j) Unit Owner(s) may retain a house sitter or caretaker during periods of Owner(s) absences. A house sitter and/or caretaker are defined as person or single families temporarily residing in and responsible for complete Units during temporary absences of the owners or lessees. They are subject to the provisions of the Bylaws and Covenants, including the Rules and Regulations of the Association.
- (k) In the event a lessee, house sitter, and/caretaker fail to comply with the Bylaws, Covenants, Rules and Regulations, or becomes a public nuisance, the Association, after notification to the Owner, may initiate action against the Owner's offending Lessee or occupant. The Association is specifically granted the power to step into

the shoes of the Owner to bring an eviction action against the Lessee/house sitter/caretaker for breach of the Lease agreement. This shall in no way limit the Association's other legal remedies. Any and all proceedings shall be taken in accordance with Edge 7 Condominium Owner's Association rules, policies, regulations, covenants and declarations. The prevailing party in such proceedings shall be entitled to an award of reasonable attorney's fee, cost of collection of the judgment and related costs.

- (l) Owners may rent or lease their residential Units to others for residential purposes. Any such lease must have a term of at least seven (7) consecutive days. If the lease term is thirty (30) days or more, the Owner shall have a written lease with their lessee that complies with the governing laws of Montana, including remitting applicable taxes to the State of Montana and the City of Livingston and shall reference compliance by the lessee with this Declaration, Bylaws, and Rules and Regulations as adopted and subsequently amended. Such written lease shall include a copy of the Rules and Regulations. Owners shall be responsible for any violation by their lessees of the Governing Documents.

7.5 **Restriction on Number of Occupants per Unit.** All Units may be used only for residential dwelling purposes and typical residential activities. No portion of the Property or Unit shall be used for living or sleeping purposes other than rooms designed for living or sleeping in a Unit. Occupancy of each Unit shall be limited to two persons per designated bedrooms in the Unit (as those bedrooms are labeled and depicted on the floor plans attached as **Exhibit G**), except that this restriction shall not be applied to preclude occupancy of a Unit by a family consisting of two persons and one or more children under the age of 18 for whom either or both of such persons are the parent, legal guardian or designee authorized in writing by the child's parent or legal custodian to care for the child. For purposes of this Section, "occupancy" means staying overnight in a Unit. Vehicles parked in excess of the limit set in the Rules and Regulations or in areas not permitted under the Rules and Regulations shall be towed at their owners' expense.

7.6 **Restriction on the Number of Units Owned by One Owner.** Any single Owner may not own more than ten percent (10%) of the total number of Units. This restriction does not apply to the Declarant.

7.7 **Home Occupation.** Notwithstanding anything to the contrary contained in this Section, a gainful home occupation, profession, trade or other non-residential use will be a permissible use of a residential Unit, so long as: (i) such use is conducted in compliance with the applicable Zoning Regulations and is not prohibited by law, (ii) such use is not restricted by this Declaration, (iii) such use is carried on entirely within a residential Unit and is secondary and incidental to its use as a residence, (iv) there is no generation of pedestrian or vehicular traffic beyond that customary or incidental to residential use of the Unit, (v) there is no use of commercial vehicles for deliveries to or from the premises, (vi) there is no on-premises sales of products, (vii) there is no external evidence of any such activity being conducted, including, but not limited to, no signs or structures advertising the occupation and no excessive or unsightly storage of materials or supplies, and (viii) the home occupation does not employ any

non-resident of the Unit, nor does it attract any non-resident customers. For guidance, the following uses are examples of potentially permissible home occupations: the making of clothing; the giving of music lessons; a sole practitioner professional practice; service or product providers who maintain a telephone and office within the residence but the services and products are not provided or sold from the Unit; the pursuit of artistic endeavors, provided that the products are not marketed and sold from the Unit, and no kilns or foundries are used in the Unit.

7.8 Activities.

- (a) Nothing shall be done or kept in any Unit or in the Common Elements which will increase the rate of insurance on the Buildings or contents thereof, without the prior written consent of the Association. No Owner shall permit anything to be done or kept in his Unit or in the Common Elements which will result in the cancellation of insurance on the Buildings, or contents thereof, or which would be in violation of any law, this Declaration, or the Association Bylaws. No waste will be permitted in the common elements.
- (b) No nuisances shall be allowed upon the Property, nor shall any use or practice be allowed which is a source of annoyance to the Owners, or which interferes with the peaceful possession and proper use of the property by its Owners. No immoral, improper, offensive or unlawful use shall be made of the property, nor any part thereof, and all valid laws, zoning ordinances and regulations or all governmental bodies having jurisdiction thereof shall be observed.
- (c) Nothing shall be done in any Unit or in, on or to the Common Elements which will impair the structural integrity of the Building or which would structurally change the Building, except as is otherwise provided herein.
- (d) Nothing shall be altered or constructed in or removed from the Common Elements, except upon the written consent of the Association.
- (e) Use by the Owners of the Units in the Project shall at all times be in compliance with all of the laws of the State of Montana. Such compliance shall also include and extend to any repair, remodeling or refurbishing of the units.

- 7.9 Animals.** No animals shall be kept, raised, or bred in any Unit. Notwithstanding the foregoing, a reasonable number of birds, dogs, cats, tortoises or other customary household pets may be brought onto the Property or kept in a Unit (“Permitted Household Pets”) as determined by the Board and defined in the Rules and Regulations. Permitted Household Pets shall not be kept, bred or maintained for any commercial purpose, nor in unreasonable quantities nor in violation of any other provision of this Declaration. Chickens are not deemed Permitted Household Pets. No Permitted Household Pet shall be permitted to harass any wildlife. Permitted Household Pets are not to be kept outside of the Unit or chained up. Any Permitted Household Pet that is on the Property shall be accompanied by the Unit Owner, or their guest or invitee, and kept under control at all times. Unit Owners

are responsible for damage and waste caused by any Permitted Household Pet associated with a Unit. The Board may establish such other reasonable Rules and Regulations (including but not limited to the number of Permitted Household Pets and the requirement to charge pet deposits) concerning Permitted Household Pets and other animals as it deems necessary. Any Unit Owner who causes any animal to be brought or kept on the Property shall indemnify and hold harmless the Association from any loss, damage or liability that the Association may sustain as the result of the presence of such animal on the Property. Nothing in this Section shall be construed to limit or prohibit therapy or service animals. However, such therapy or service animals shall be registered with the Board, and the Member owning such animal shall provide the Board with the written recommendation of a medical professional verifying the need for the animal, as well as the animal's training certificate or other qualification(s). All animals must be kept in compliance with this Declaration, the Edge 7 Rules, or the Belgrade City Code.

- 7.10 **Aesthetics.** The Common Elements (including Limited Common Elements appurtenant to the Units) shall not be used for storage of supplies, recreational equipment, materials, personal property or trash or refuse of any kind, except as provided in duly adopted Rules and Regulations. No unsightly conditions shall be maintained on the patio, porch, terrace or deck of any Unit or in any other area that is visible from the exterior of the Unit and only furniture and equipment consistent with the normal and reasonable use of such areas shall be permitted to remain there. During seasons when not reasonably in use, such furniture and equipment may be neatly covered and stored on the patio, porch, terrace, or deck of a Unit. The Board may adopt Rules and Regulations from time to time addressing the exterior appearance of Units and Buildings and the use of porches, decks, balconies, terraces and patios. In general, no activity shall be carried on nor condition maintained by a Unit Owner, either in a Unit or upon the Common Elements, which is detrimental to the appearance of the Project.
- 7.11 **Trash.** No trash, waste, garbage, litter, junk, refuse, or unused items of any kind shall be kept, stored, thrown, dumped, allowed to accumulate, left or burned on any portion of the Property. No incinerator or other device for burning of trash or garbage shall be installed or used. Each Member shall store household trash within his, her, or its Unit and/or the appurtenant garage, and shall dispose of their trash at the location(s) designated by the Association. At no time should trash be stored outdoors.
- 7.12 **Advertising and Signage.** Owners shall not cause or permit anything to be hung or displayed on the outside of windows or placed on the outside walls of a building and no air conditioning, sign, awning, canopy, radio or television antenna, satellite dish larger than eighteen inches (18") in diameter. No signs or other advertising devices of any kind shall be displayed which are visible from the exterior of a Unit or on the Common Elements, including, but not limited to, any real estate sign, "for rent" sign, without written permission from the Board.
- 7.13 **Parking.** No vehicles may be stored anywhere on the Property except in garages and on the limited common element driveways. However, if a vehicle is parked in a driveway, it cannot be parking in such a way that it impedes the existing sidewalk.

- 7.14 **Lights.** Except as otherwise regulated in the Zoning Regulations or Governing Documents, the Board may adopt Rules and Regulations regulating exterior lighting or seasonal or holiday lighting.
- 7.15 **Marijuana.** No part of the Property may be used for the growing of, storage of, sale, dispensing, or other transfer of marijuana (medical or recreational) for any purpose, including, but not limited to, marijuana which is grown, harvested, and distributed pursuant to any law that authorizes or licenses any of the foregoing activities.
- 7.16 **Satellite Dishes/Antennas.** No external antennas are allowed. Satellite dishes up to eighteen inches (18") are allowed. An Owner shall use his best efforts to shield satellite dishes from ground level view and shall integrate such dish into the overall roof design (if roof mounted) or external siding. Owners shall receive approval from the Board prior to the placement of any satellite dish. Association approval will not be unreasonably withheld, but is required to make sure the placement of the satellite dish complies with its Rules and Regulations and to make sure that placement does not violate the health, safety, and welfare of any other Owner. Any damage to the Common Elements will be paid for by the Unit Owner.
- 7.17 **Handicapped Rights.** Subject to the review rights of the Association and applicable law, each Owner shall have the right to modify his Unit and the route to his Unit (as applicable and necessary) leading to the entrance of his Unit, at his sole cost and expense, in order to facilitate access by Persons who are blind, visually handicapped, deaf or physically disabled, or to alter conditions which could be hazardous to such Persons.
- 7.18 **Water & Sewer System.** All Units shall be served by the water and sewer departments of the City of Belgrade, Montana, or their successors and assigns. One (1) city water meter shall serve each Building. All Owners and other persons having an ownership interest in a Unit shall be obligated to pay the required water and wastewater fees for those services. The Association shall determine the cost of water and wastewater fees per Unit. Failure to pay the fees for services may result in services being shut off to the Unit.

8 - INSURANCE

- 8.1 **Association Policies.** All insurance policies upon the Common Elements and the Units shall be purchased by the Association and shall be insured by an insurance company authorized to do business in Montana.
- (a) **Named Insured – Association Insurance.** The named insured under all policies purchased by the Association shall be the Association individually as agent for the Unit Owners. However, the property insurance maintained by the Association shall include, where so required, each Unit Owner and their lenders or mortgagees as additional insureds as their interests may appear, with standard mortgagee clause in favor of each listed mortgagee, subject however, to loss payment and other provisions as are set forth by these documents. Such property insurance policies shall provide that payments for losses thereunder by the insurer shall be paid to the

Insurance Trustee hereinafter designated, and all policies and endorsements thereon shall be deposited with the Insurance Trustee.

- (b) **Copies to Owners.** Upon written request by a Unit Owner, the Association shall furnish one copy of each insurance policy and of all endorsements to such Unit Owner. The Association shall also provide, upon written request, certificates of insurance evidencing property and liability insurance to each Unit Owner and/or their lender/mortgagee where required.

8.2 **Coverage.** The Association shall obtain and continue in effect the following types of insurance, if reasonably available, or if not reasonably available, the most nearly equivalent coverages as are reasonably available (as determined by the Board):

- (a) **Property Insurance.** All Units and Buildings, including the Common Elements and such portions of the Units as are for insurance purposes normally deemed to constitute part of the Common Elements and such other improvements to land as may be included in the Common Elements and where such improvements are reasonably insurable under a property policy, shall be fully insured to an amount equal to the full replacement cost thereof with all such insurance to be based on current replacement cost value, as determined annually by the Board, but subject to such deductible clauses as are required in order to obtain and maintain coverage at reasonable costs, and which coverage shall be increased by the Board as may be necessary to provide that the insurance proceeds will be sufficient to cover replacement, repairs or reconstruction. Such coverage for the Units shall be pursuant to so called "all in" property insurance policies (except as itemized below). Such coverage shall afford protection against the following:
 - (i) loss or damage by fire and other hazards typically covered by a standard special cause of loss property policy form or its equivalent; and
 - (ii) specifically, such other perils, including flood and earthquake, as from time to time may be customarily covered with respect to buildings similar in construction, location and use as the Buildings, if the Association so desires, in amounts to be determined by the Board; and
 - (iii) the policies shall cover the Units as initially installed in accordance with Declarant's original plans and specifications or a replacement of like kind and quality, such property to include, but not be limited to, the building/structure, air-handling equipment for space cooling and heating, service equipment such as dishwasher, disposal, laundry, fireplaces, refrigerator, stove, oven, interior fixtures such as electrical and plumbing fixtures, installed floor coverings, inside paint and other wall finishing, each of which become part of the building, regardless of whether such items are included within the definition of Common Elements. Alterations, betterments or improvements added by or at the request of Owners after

initial construction and installation of the Unit which are greater than Ten Thousand Dollars and Zero Cents (\$10,000.00) in value shall not be automatically covered by the Association master property insurance policies unless such alterations, betterments and improvements are true replacements of like kind and quality to that of the initial installation and any alterations, betterments and improvements beyond that must be specifically presented to and accepted in writing by the Association (as determined by the Board) in order to be added to the Association policy. Prior to any such acceptance by the Association, the Owner shall be fully responsible for such alterations, betterments and improvements and all related insurance. In addition, the Association's property policy shall not include insurance coverage for any Unit Owner's personal property, furnishings and/or contents and none of the Association, the Board, the Manager or Declarant shall have any responsibility or liability with respect to such items.

- (iv) During any period when any repair or reconstruction of a Building or Unit is taking place, and to the extent such coverage is not included in the above required property insurance policy, a Builders Risk policy shall be maintained for the completed value of the Building or Unit with coverages equivalent to those included in the paragraph above.
- (v) All property insurance policies carried by the Association shall provide for waivers of subrogation of claims against the Unit Owners and occupants of any Unit.
- (b) **Workers Compensation.** Workers compensation as required by law and employer's liability insurance with respect to officers and employees of the Association, if applicable.
- (c) **Director's and Officer's Liability.** Unless otherwise determined by the Board, a directors and officers liability insurance policy with a limit of not less than One Million Dollars and Zero Cents (\$1,000,000.00) (or such higher limit as may be determined by the Board) to insure against liability for actions taken by individuals in their capacity as officers or directors of the Association.
- (d) **General Liability.** Commercial general liability insurance on an occurrence form covering bodily injury, including death, and property damage with a limit of not less than One Million Dollars and Zero Cents (\$1,000,000.00) per occurrence and Two Million Dollars and Zero Cents (\$2,000,000.00) in the aggregate and including coverage for personal injury, products and completed operations and contractual liability. Such insurance shall cover and indemnify the Association, the Board, the Manager, if any, and each director, officer and employee of the foregoing against liability for all tort claims arising out of or relating to the Association's ownership, operation, use and maintenance of the Project; and such policy may include, where available, the Unit Owners as additional insureds; provided, however, that such

insurance is not intended to contribute to or be in lieu of any individual Unit Owner's liability policies required to be carried by each Unit Owner as stipulated below and under which each Unit Owner's liability insurance shall be primary for each respective Unit Owner.

- (e) **Fidelity Bond.** Fidelity and crime insurance with a limit of One Million Dollars and Zero Cents (\$1,000,000.00) or such other limit as may be determined by the Board, covering officers and employees of the Association who handle or are responsible for its funds, if applicable.
- (f) **Other Insurance.** Such other insurance as the Board shall determine from time to time to be desirable and as may be required by the Federal and State laws.
- (g) **Insurance Changes.** If the Board determines that it is not in the best interest of the Association for the Association to maintain property insurance on the Units, due to cost or otherwise, the Board may amend this Declaration to reduce or eliminate the Association's obligation to maintain such insurance and to require each Unit Owner to maintain property insurance on such Unit Owner's Unit for full replacement value. Such amendment may include such additional requirements and limitations relating to such insurance as the Board deems reasonable and may include provisions addressing use of insurance proceeds and repair or reconstruction in the event damage to or destruction of a Unit. The Board may cause such amendment to be prepared and recorded without the consent of the Unit Owners; *provided, however*, notice shall be provided to each Unit Owner a reasonable time, not to be less than forty-five (45) days, in advance of such change in order to allow each Unit Owner time to obtain such newly required property insurance.

8.3 **Claims Against the Association's Insurance Policies.** Unless otherwise provided in this Declaration or the Bylaws, the Board may adopt a resolution that:

- (a) Prescribes a procedure for processing insurance claims. The procedure may require that all claims against the Association's insurance policy be processed through and coordinated by the Board or the Manager, if authorized by the Board.
- (b) Assigns the responsibility for payment of charges for handling claims, including any charges by a Manager.

8.4 **Premiums and Deductibles.** Premiums upon insurance policies obtained by the Association shall be paid by the Association as a Common Expense, except that the amount of increase in the premium that is incurred or occasioned by the negligence, willful misconduct, occupancy, or abandonment of a Unit or its appurtenances or of the Common Elements by a Unit Owner (or a Unit Owner's invitees or guests) shall be assessed against that Owner or any other person having an ownership interest in the Unit. Any unpaid amounts shall be treated as an unpaid assessment in accordance with this Declaration. Not less than ten (10) days prior to the date when a premium is due, evidence of such payment

shall be furnished by the Association to each lienholder listed in the roster of lienholders if requested in writing by such lienholder. In the event of an insured loss, the amount of any deductible paid in connection therewith shall, in the discretion of the Board, either (a) be treated in the same manner as the premiums for the applicable coverage, (b) be assessed to one or more Unit Owners or other persons having an ownership interest in the applicable Unit(s) as such loss circumstances may equitably warrant, or (c) be assessed to a specific Unit Owner or other person having an ownership interest in the applicable Unit(s) if the loss resulted from the negligence or willful misconduct of a Unit Owner or such other person (or a Unit Owner's or such other person's family, invitees or guests). The Board is authorized to collect as part of the Common Expense an amount to fund a reserve equal to the deductible for each insurance policy maintained by the Association. The intent is to therefore, reduce the annual premium for said policies by allowing for a higher deductible.

8.5 **Policy Requirements.** From time to time, the Association shall arrange for a review of the sufficiency of its insurance coverage by one or more qualified persons, at least one of whom must be familiar with insurable replacement costs in Gallatin County, Montana. The policies may contain a reasonable deductible. All insurance coverage obtained by the Board shall (if reasonably available):

- (a) Be written with a company authorized to do business in Montana;
- (b) Be written in the name of the Association as trustee for the benefitted parties. Policies on the Condominium shall be for the benefit of the Association and its Owners;
- (c) Not be brought into contribution with insurance purchased by Owners, occupants or their mortgagees individually;
- (d) Contain an inflation guard endorsement;
- (e) Include an agreed amount endorsement, if the policy contains a co-insurance clause;
- (f) Provide that each Owner is an insured person under the policy with respect to liability arising out of such Owner's interest as a member of the Association in the Condominium (provided, this provision shall not be construed as giving an Owner any interest in the Condominium other than that of an Owner);
- (g) Include an endorsement precluding cancellation, invalidation, suspension, or non-renewal by the insurer on account of any act or omission of one or more Owners, or on account of any curable defect or violation of any Owner without prior written demand to the Association to cure the defect or violation and allowance of a reasonable time to cure; and
- (h) Include an endorsement precluding cancellation, invalidation, or condition to recovery under the policy on account of any act or omission of any one or more

individual Owners, unless such Owner is acting with the scope of its authority on behalf of the Association.

8.6 **Waiver of Subrogation and Endorsements.** In addition, the Board shall use reasonable efforts to secure insurance policies which name the Owners, collectively, as additional insureds for claims arising in connection with the ownership, existence, use or management of the Condominium and provide:

- (a) A waiver of subrogation as to any claims against the Association's Board, staff, officers, and any manager, the Owners and their invitees;
- (b) A waiver of the insurer's rights to repair and reconstruct instead of paying cash;
- (c) An endorsement excluding Owners' individual policies from consideration under any "other insurance" clause;
- (d) An endorsement requiring at least thirty (30) days' prior written notice to the Association of any cancellation, substantial modification, or non-renewal;
- (e) A cross-liability endorsement that provides cross-liability coverage; and
- (f) A provision vesting in the Board exclusive authority to adjust losses; provided however, no Mortgagee having any interest in such losses may be prohibited from participating in the settlement negotiations, if any related to the loss.

8.7 **Insurance Trustee.** The Board shall have the exclusive authority to make a claim and adjust a loss under policies purchased by the Association. Upon such election being made by the Board, the Board shall provide that all proceeds covering property losses shall be paid to such bank in Montana with trust powers as may be designated as insurance trustee by the Board, which trustee is herein referred to as the "**Insurance Trustee.**" The Insurance Trustee shall not be liable for payment of premiums nor for the renewal or the sufficiency of policies nor for the failure to collect any insurance proceeds. The duty of the Insurance Trustee shall be to receive such proceeds as are paid and hold the same in trust for the purposes elsewhere stated in this Declaration and for the benefit of the Unit Owners and their mortgagees in the following shares, but which shares need not be set forth in the records of the Insurance Trustee.

- (a) **Unit Owners.** Where all Units are destroyed, an undivided share for each Unit Owner, such share being the same as the Percentage of Interest appurtenant to each Unit. In the event less than all Units are damaged or destroyed, then such proceeds shall be held only for the Owner(s) of the damaged or destroyed Unit(s) to the extent of the repair costs of the damage or in the event of destruction, to the extent of the fair market value of the Unit before the destruction. In the event Common Elements are damaged or destroyed, then the proceeds with respect to such Common Elements shall be held for the Owners in accordance with their interests in such Common Elements.

- (b) **Mortgagees.** In the event a mortgagee endorsement has been issued as to a Unit, the share of the Unit Owner shall be held in trust for the mortgagee and the Unit Owner as their interests may appear; *provided, however*, that no mortgagee shall have any right to determine or participate in the determination as to whether or not any damaged property shall be reconstructed or repaired, and no mortgagee shall have any right to apply or have applied to the reduction of a mortgage debt any insurance proceeds except distributions thereof made to a Unit Owner and mortgagee pursuant to the provisions of this Declaration.

8.8 **Unit Owners' Insurance.** Each Unit Owner shall procure and maintain, and shall provide the Board upon request with a certificate of insurance showing that the Unit Owner has in full force and effect (provided that the Board shall have no obligation to request such certificates or to monitor Unit Owner insurance, and none of the Association, the Board or Declarant shall have any liability with respect thereto), the insurance itemized below, which shall be maintained on a primary basis, and the cost of which shall be the sole and exclusive responsibility of the Unit Owner:

- (a) Property insurance for the Unit that provides coverage for what is not covered by the policy maintained by the Association as referenced above.
- (b) Liability insurance on an occurrence form against claims for bodily injury, death or property damage occurring on, in or about the Unit and insuring the Unit Owner's liability with a limit of not less than One Million Dollars and Zero Cents (\$1,000,000.00).

Each Unit Owner shall have the right to carry other insurance for such Unit Owner's own benefit. All policies carried by the Unit Owners (a) shall contain waivers of subrogation of claims against the Association, its officers and directors; and (b) shall not adversely affect or diminish any liability under any insurance obtained by the Association. Each Unit Owner may seek to add Deductible Assessment coverage to their personal insurance policy form, where available and at the sole cost of such Unit Owner, to cover those potential Association deductibles which may be assessed to any one or more Unit Owner.

8.9 **Distribution of Proceeds.** Proceeds of insurance policies received by the Insurance Trustee shall be distributed to or for the benefit of the beneficial Owners in the following manner:

- (a) **Miscellaneous.** Expenses of administration, Insurance Trustee and construction or remodeling supervision shall be considered as part of the cost of construction, replacement or repair.
- (b) **Reconstruction or Repair.** Any balance remaining shall be used for reconstruction and repair as hereafter provided.
- (c) **Partial Reconstruction.** If the Unit or Units or Common Elements are destroyed

and partially rebuilt, distribution shall be made to Unit Owners or the Insurance Trustee as their interests appear based on the reconstruction of the Units and Common Elements.

- (d) **No Reconstruction or Repair.** If there is no reconstruction or repair, the first proceeds for distribution after paying the Insurance Trustee shall be made to the first lienholders for such Units before distribution to the Unit Owners.
 - (e) **Remaining Proceeds.** After distribution of the insurance proceeds as set forth above, any remaining proceeds shall be distributed to the Units Owner(s) as such Owner(s) interest shall appear. In the event less than all Units are damaged or destroyed, then such proceeds shall be held only for the Owner(s) of the damaged or destroyed Unit(s) to the extent of the repair costs of the damage or in the event of destruction, to the extent of the fair market value of the Unit before the destruction. To the extent Common Elements are damaged or destroyed then remaining proceeds shall be held for the Owners in accordance with their interests in such Common Elements.
 - (f) **Certificate.** In making distribution to Unit Owners and their lienholders, the Insurance Trustee may rely upon a certificate of the Association made by the Board or Manager as to the names of the Unit Owners and their respective shares of the distribution.
- 8.10 **Board as Agent.** The Board is irrevocably appointed agent for each Unit Owner and for each owner of a mortgage or other lien upon a Unit and for each owner of any other interest in the Project to adjust all claims arising under insurance policies purchased by the Association and to execute and deliver releases upon the payment of claims.
- 8.11 **Benefit to Mortgagees.** Certain provisions in this Article are for the benefit of mortgagees or trust indenture beneficiaries, and all such provisions are covenants for the benefit of any mortgagee or trust indenture beneficiary of a Unit and may be enforced by such mortgagee or beneficiary.
- 8.12 **Notice to Lienholder.** The Unit Owners, and not the Board nor the Association, shall notify the holder of any first lien on any of the Units of the occurrence of any loss in excess of Ten Thousand Dollars and Zero Cents (\$10,000.00) within thirty (30) days of such loss.
- 8.13 **Reconstruction.**
- (a) **Repair after Casualty.** If any part of the Project shall be damaged by casualty, whether or not it shall be reconstructed or repaired shall be determined in the following manner:
 - (i) **Lesser Damage.** If a Unit or Units (or other damaged property within the Project) is found by the Board to be tenantable after the casualty, the damaged property shall be repaired.

- (ii) **Greater Damage.** If a Unit or Units (or other damaged property within the Project) is found by the Board to be not tenable after the casualty, the damaged property may be reconstructed or rebuilt as provided in the applicable provisions of the Act. If the decision is made not to rebuild then the property shall be subject to the applicable provisions of the Act.
 - (iii) **Election not to Rebuild.** If a Unit or Units (or other damaged property within the Project) is found by the Board to be not tenable after the casualty and the Association elects not to rebuild as herein provided and set forth in 70-23-803, MCA, and less than all of the Units have been damaged or destroyed, following any payments required by 70-23-805, MCA, the Insurance Trustee shall be instructed to disburse the proceeds in accordance with paragraph 9.9(d) and 9.9(e).
 - (iv) **Certificate.** The Insurance Trustee may rely upon a certificate of the Association made by the Board or Manager to determine whether or not the damaged property is to be reconstructed or rebuilt.
- (b) **Plans and Specifications.** Any reconstruction or repair must be substantially in accordance with the plans and specifications for the original improvements, or if not, then according to plans and specifications approved by not less than seventy-five percent (75%) of the Unit Owners, including the Owners of all Units the plans for which are to be altered, and in accordance with the review and approval requirements set forth in the Design Guidelines. Any such reconstruction not in accordance with the original plans and specifications must be set forth in an amendment to the Declaration. Provided that any consents required by the Governing Documents in connection with reconstruction not in accordance with the original plans and specifications have been obtained, the Board may cause to such amendment to be prepared and recorded without the consent of the Unit Owners.
- (c) **Responsibility.** The responsibility for reconstruction or repair after casualty shall be that of the Association which shall work with the Insurance Trustee to carry out the provisions of this Article 9.
- (d) **Assessments.** If the proceeds of insurance are not sufficient to defray the estimated costs of reconstruction or repair for which the Association is responsible, or if at any time during such reconstruction or repair, or upon completion of such reconstruction or repair, the funds for the payment of the costs thereof are insufficient, assessments shall be made against all Unit Owners in sufficient amounts to provide funds to cover the payment of such costs. Such assessments shall be in proportion to the Owner's Percentage of Interest, unless such reconstruction or repair resulted from the negligence or willful misconduct of an Owner or the family member, guest or invitee of an Owner, in which case such amounts may, in the discretion of the Board, be assessed against such Owner or other person having and ownership interest in the applicable Unit.

- (e) **Construction Funds.** The funds for payment of costs of reconstruction or repair after casualty, which shall consist of proceeds of insurance held by the Insurance Trustee and funds collected by the Association from assessments against Unit Owners, shall be disbursed in the sound discretion of the Insurance Trustee and according to the contract of reconstruction or repair, which contract must have the approval of the Board.
- (f) **Surplus.** It shall be presumed that the first monies disbursed in payment of costs of reconstruction and repair shall be from the insurance proceeds. If there is a balance in a construction fund after payment of all costs of the reconstruction and repair for which the fund is established, such balance shall be paid to the Association for the use and benefit of the Unit Owners.

8.14 **Condemnation.**

- (a) In the event the Common Elements, or any portion thereof, shall be taken for any public or quasi-public use, under any statute, by right of eminent domain or by purchase in lieu thereof, each Owner will be entitled to notice thereof, but the Association (acting through the Board) will act as attorney-in-fact for all Owners in the proceedings incident to such taking unless otherwise prohibited by law. The award for such taking will be payable to the Association as trustee for all of the Owners to be used as follows:
 - (i) If the taking involves a portion of the Common Elements on which improvements (not including a Unit) have been constructed, then, unless (a) restoration or replacement of such improvements would be illegal under any applicable law, rule, regulation or ordinance or (b) within sixty (60) days after such taking, the Board elects not to restore or replace such improvements, the Association shall restore or replace such improvements so taken on the Common Elements to the extent lands are available therefore, in accordance with plans approved by the Board and, to the extent required by applicable law, any governmental or quasi-governmental entity having jurisdiction over the Property. If such improvements are to be restored or replaced, and the award for the taking is insufficient to restore or replace such improvements, the Board shall levy a special assessment, payable by the Unit Owners in accordance with their Percentage of Interest, in the aggregate amount of such deficiency and shall proceed to restore or replace such improvements.
 - (ii) If the taking does not involve any Common Elements including improvements, or if there is a decision made not to restore or replace as set forth above, or if there are net funds remaining after any such restoration or replacement of improvements is completed, then the Association shall retain such excess proceeds and place them in the Association's reserve account.

- (b) In the event any Unit or any portion thereof shall be taken, the condemnation award for such taking shall be paid solely to the Unit Owner(s) of such Unit(s). If an entire Unit shall be condemned, the Unit Owner thereof shall automatically cease to be an Owner or a member of the Association with respect to such Unit, but obligations arising prior to such taking shall remain the obligation of such person or entity regardless of the termination of membership.

ARTICLE 9 - MORTGAGEE PROVISIONS

9.1 **Notice of Action.** Any institutional holder, insurer, or guarantor of a first mortgage that provides a written request to the Association in accordance with this Article shall thereby become an “Eligible Holder” for so long as such Person remains an institutional holder, insurer or guarantor of a first mortgage and will be entitled to timely written notice of:

- (a) Any condemnation loss or any casualty loss of which the Association has notice which affects a material portion of the Common Elements; or
- (b) Any foreclosure by the Association of a lien resulting from a delinquency in the payment of any Assessment, charge, fine, penalty or other amount payable by an Owner with respect to a Unit subject to the mortgage of such Eligible Holder. Such notice shall be given at least thirty (30) days prior to the foreclosure.
- (c) The written request as required under this Article shall clearly state the legal description and address of the Unit as well as the name, mailing address, telephone number and e- mail address of the person who should receive the notices for the above listed actions. It is the sole obligation of the Eligible Holder to keep this information up to date with the Association and deliver notice as provided herein to the Association when this information changes. The Association will not be in default for failure to provide the above-listed notices if the Eligible Holder does not provide the Association with accurate information.
- (d) Any written notice required under this Article to be provided by the Association to an Eligible Holder shall be in writing and shall be deemed to have been duly given if delivered personally or if sent by certified mail, first-class, postage pre-paid, return receipt requested to the address provided by the Eligible Holder or by an acknowledged email.

ARTICLE 10 - REMOVAL, PARTITION, AND SUBDIVISION

The Project may only be removed from condominium ownership, and may only be partitioned or sold upon compliance with each of the conditions hereof:

10.1 Board Approval. The Board must approve the plans of removal, partition or sale, except for the rights reserved to Declarant contained in this Declaration. Such approval shall

include the details of how any partition or sale, and the distribution of property or funds, shall be accomplished.

- 10.2 Member Approval.** The plan of removal, partition, subdivision, abandonment, termination or sale must be approved as provided in the Act. If approval for any of the forgoing is not required by the Act, then approval shall be required from Owners representing one hundred percent (100%) of the Percentage of Interest and any related first lienholder in the Project. Upon obtaining such approval, the Board shall be empowered to implement and carry out the plan of removal, partition, subdivision, abandonment, termination or sale. This provision is subject to the rights reserved to Declarant contained in this Declaration.
- 10.3 Division of Units.** No Unit may be divided or subdivided into a smaller Unit, nor any portion thereof sold or otherwise transferred, except as provided above.
- 10.4 Common Elements.** The Common Elements shall not be abandoned, partitioned, subdivided, encumbered, or sold or transferred (except to the Association) without compliance with all of the above requirements. This provision does not apply to fixtures attached to the General Common Elements that may be disposed of pursuant to the Board's discretion. By way of example but not limitation, the Board may decide to dispose of a park bench that has become unsafe or exceeded its useful life.
- 10.5 Removal or Partition – Subdivision.** The plan of removal or partition, abandonment, termination or sale, other than condemnation, shall be agreed to by: (1) eligible mortgage holders that represent at least sixty-seven percent (67%) of the votes of the mortgaged Units, or by the votes specified in the Act, whichever is greater; and (2) at least seventy-five percent (75%) of the Unit Owners by the votes specifies in the Act, whichever is greater. Upton obtaining such approvals, the Board shall be empowered to implement and carry out the plan of removal, partition, abandonment, termination or sale.

ARTICLE 11 - DECLARANT'S RIGHTS

In addition to those rights contained throughout this Declaration, the Declarant specifically reserves the following:

- 11.1 Changes to Project.** The Declarant reserves the right to change the exterior design, interior design and arrangement of all Units, so long as the Declarant owns the Units so altered. No such change shall increase the number of Units or alter the boundary of the general common elements without an amendment of this Declaration, but may alter Owners' Percentages of Interest based on the final square footage of the Condominium Units. Until seventy-five percent (75%) of the units, including the expansion Units, have been built and sold, Declarant reserves the right to establish easements, reservations, exceptions and exclusions consistent with the Edge 7 Condominiums project. Further, notwithstanding any other provision(s) expressly or impliedly to the contrary contained in this Declaration, the Articles of Incorporation or Bylaws of the Association, Declarant reserves the right to exercise the rights, duties and functions of the Board of Directors of

the Association until seventy-five percent (75%) of the all the Units, including expansion Units, in Edge 7 Condominiums have been built and sold. During the period of development and sale of the Units, the monthly assessment from Common Expenses shall be based upon the estimate of the actual cost thereof, excluding therefrom any estimated amount for contingencies, reserves or sinking funds, and Declarant shall pay its pro rata share thereof only for those Units which have been completed. During the period of time when fewer than all of the Units, including expansion Units, have been built and approved for occupancy: (1) the Common Expenses shall be allocated based on each Unit Owners Percentage of Interest in the General Common Elements; and (2) Declarant shall pay the real estate taxes and assessments on that portion of the Property which remains undeveloped but on which Units will be subsequently constructed.

11.2 Expansion Provisions. The Declarant intends from time to time to construct additional Units on the Property, for a final total not to exceed one hundred and sixty (160) units. This includes the ability to change a Land Lot Unit to Buildings, Units or any other type of Unit. At such time as Declarant wishes to add such additional Units or amend the Land Lot Units, Declarant shall record in the office of the Clerk and Recorder of Gallatin County, Montana, a supplemental declaration containing the following information which is not mentioned herein:

- (a) If different from the attached Exhibit C:
 - (i) A site plan showing the Building or Buildings to be constructed on the Common Elements as the same is set forth herein showing the site plan and common elements as the same is set forth herein showing the site plan and common elements of the condominium; and
 - (ii) A designation of the Buildings to be constructed with the same to be shown on the site plan to be so recorded.
- (b) If different from the attached Exhibit :
 - (i) Floor plans showing the Units to be contained within the additional Buildings to be constructed and added to this Project together with the numbers given to the specific Units.
 - (ii) A description of the Buildings and materials of which they are constructed;
- (c) A schedule of the percentage of undivided ownership of the specific Units to be added to the Project in the General Common Elements, computed for each Unit which, when added to the number of Unites as a whole, will give the additional Units, as well as the previously existing Units, their respective percentages of interest in the expanded or new Project.
- (d) To be and remain in compliance with the provision of M.C.A. § 70-23-306 at the time of the filing of such amendment or amendments, floor plans and a certificate

of floor plans shall additionally be prepared and recorded, being additions to Exhibit E & G, certifying and showing that the said floor plans fully and accurately depict the layout of the Units in the floors of the Buildings and that construction of each such additional new Building will be completed as depicted or was completed as depicted; and

- (e) A description of any and all limited common elements to the new Units if there shall be any changes to the description contained in the existing Declaration or any of the amendments thereto.
- (f) At the time the Declarant, or its successors or assigns, elects to file such amendment to this Declaration, all then existing condominium owners hereby covenant and agree that they will upon request, join in the execution of such amendment papers agreeing, consenting and joining in such amendment, and further agreeing to reduce their percentage of ownership interest in the common elements.
- (g) The within agreement shall be a covenants running with the land, and shall be binding upon the Owner of the then existing Units, who upon acquiring title to such Unit, by this Covenants agree and consent to the filing of such amendment and join in the same, and by this covenant agree and consent to the appointment of the Declarant as their attorney-in-fact so that the Declarant may in his discretion simply file the supplemental Declaration on his own initiative, having been herein given the power and authority to make such amendment for and on behalf of all subsequent condominium owners in Edge 7 Condominiums.
- (h) After the recording of such supplemental and amended Declarations, all owners of Units in the Property shall have a non-exclusive right and license subject to the provisions herein, to use and enjoy all of the general common elements of the property and all of the general common elements added to the Project by such amendment. In addition, the owners of the respective Units shall further have the nonexclusive right and license to use and enjoy the limited common elements which are appurtenant and part of their respective Units which may be added to the Project which are limited to the use of less than all of the Unit Owners.
- (i) Except as otherwise specifically provided in this Declaration or in such Supplemental Declaration, all of the provisions, terms and definitions herein contain shall, upon recording of the same, be deemed expanded to include the additional Units.

11.3 Timeframe for Completion. Declarant shall not be required to construct all proposed Condominium Units (including Annexable Property) within any set time frame. Declarant reserves the right to build the Condominium Units in accordance with the floor plans and site plan attached hereto and as the same may be amended in accordance with this Declaration. When a Condominium Unit is completed, the Declarant shall record in the Public Record an amendment to this Declaration to which shall be attached a verified certificate or statement of a registered

architect, registered professional engineer, or registered land surveyor certifying that the floor plan previously filed or being filed simultaneously with the amendment fully and accurately depicts the layout of the Units and the date of construction completion. If there is any change in the Floor Plans, Site Plan, or Owners' Percentage of Interest in the Common Elements, then the amendment shall include such changes.

11.4 Assessments. Until a Condominium Unit is complete, and the amendment is recorded, the Declarant shall not be charged for Assessments on the Condominium Unit. Declarant may voluntarily subsidize the Association's budget. Such subsidy shall be limited to Common Expenses for the General Common Elements relating to the land, including real estate taxes, public liability insurance, road maintenance (including snow plowing), landscaping maintenance, and other Common Expenses relating to the General Common Elements, but not including Common Expenses for maintenance, fire and casualty insurance, or other Limited Common Expenses relating to the Limited Common Elements applicable to or servicing only completed Condominium Units.

11.5 Assignment. Any or all of the rights and powers granted or reserved to Declarant in this Declaration or by law, including the power to approve or disapprove any act, use, or proposed action, or any other matter or thing, may be assigned by Declarant to any other entity or to the Association. Any such assignment or transfer shall be made by appropriate instrument in writing duly recorded in the office of the Clerk and Recorder of Gallatin County, Montana.

ARTICLE 12 - ENFORCEMENT AND REMEDIES

11.3 Procedure. The Association shall have the right (but not the obligation) to enforce the provisions of any of the Governing Documents, through procedures adopted by resolution of the Board, abatement of the violation by the Association, or by proceedings either at law or in equity against any Person(s) violating or attempting to violate any of the Governing Documents.

11.4 Discretion. The decision to have the Association pursue enforcement action in any particular case shall be left to the Board's discretion, except that the Board shall not be arbitrary or capricious in taking enforcement action. Without limiting the generality of the foregoing sentence, the Board may determine that, under the circumstances of a particular case:

11.4.1 the Association's position is not strong enough to justify taking any or further action; or the covenant, restriction or rule being enforced is, or is likely to be construed as, inconsistent with applicable law; or although a technical violation may exist or may have occurred, it is not of such a material nature as to be objectionable to a reasonable person or to justify expending the Association's resources; or it is not in the Association's best interest, based upon hardship, expense, or other reasonable criteria, to pursue enforcement action. Such a decision shall not be deemed a waiver of the right of the Association to enforce such

provision at a later time under other circumstances or preclude the Association from enforcing any other covenant, restriction or rule, nor shall it preclude any Owner from taking action at law or in equity to enforce this Declaration.

11.5 **Costs of Enforcement.** Costs incurred for enforcing the provisions of the Governing Documents (inclusive of giving notice of the violation), costs of correcting the defect or undoing the violation, if undertaken by the Association, or any fines levied against the Owner after the Owner or his/her tenants, guests and/or invitees is determined by the Board to be in violation of the Governing Documents shall be paid by the Owner. Any costs incurred for enforcing the provisions of Governing Documents, for correcting the defect or undoing the violation, or fine assessed against the Owner that is not paid within sixty (60) days as provided herein shall result in a lien being recorded against the Unit and/or the Owner's interest therein, such lien to be enforceable by sale under the laws of the State of Montana. Such lien will be recorded in the office of the Clerk and Recorder in Gallatin County, Montana. Should any lawsuit, arbitration or other legal proceeding be instituted by the Association against an Owner alleged to have violated one or more of the provision of the Governing Documents and should the Association be wholly or partially successful in such proceeding, the offending Owner shall be obligated to pay the costs of such proceeding, including reasonable attorney's fees, costs, and cost of collecting the judgment.

11.6 **Delegation.** The Board may delegate any of its rights or obligations with respect to enforcement as set forth above to its appointed agent, or any committee of the Board, including, but not limited to, the Manager; except that any decision to pursue or not pursue any legal proceeding may not be delegated, and shall be determined by the Board.

11.7 **Remedies Cumulative.** All remedies provided for in this Declaration and the other Condominium Documents shall not be exclusive of any other remedies which may now be, or are hereafter, available to the parties hereto as provided for by law.

11.8 **Joint and Several Liability.** In the case of joint ownership of a Unit, in any form, the liability of each Owner thereof in connection with the liabilities and obligations of Owners as set forth in or imposed by the Governing Documents shall be joint and several.

ARTICLE 12 - AMENDMENT

11.9 **Amendment By Declarant.** The Declarant may unilaterally amend this Declaration or any other project document (i.e. Bylaws, Rules and Regulations) until seventy-five percent (75%) of all of the Units, including the expansion Units, in the Project, have been sold.

11.10 **Amendment By Board.** The Board may unilaterally amend this Declaration if such amendment is (i) necessary to bring any provision in compliance with any applicable governmental statutes, necessary governmental registrations, rule, regulation, or judicial determination; (ii) necessary to enable any reputable title insurance company to issue title insurance coverage on the Units; (iii) required by an institutional or governmental lender or purchaser of mortgage loans, to enable such lender or purchaser to make or purchase mortgage loans on the Units; (iv) necessary to enable any governmental agency or

reputable private insurance company to insure mortgage loans on the Units or to insure the Project or any portion thereof, including any individual Unit; (v) necessary to allow the Association to obtain insurance contemplated by this Declaration, including, without limitation, property or liability insurance, at a reasonable price and on reasonable terms; or (vi) otherwise necessary to satisfy the requirements of any governmental or quasi-governmental agency.

11.11 Amendment By Owners.

- (a) This Declaration may be amended by the affirmative vote or written consent, or any combination thereof, of at least sixty percent (60%) of the Unit Owners. If the Declarant still Controls the Project, the amendment must be approved by the Declarant.
- (b) **Application.** Owners are on notice that by virtue of taking title to a Unit subject to the Governing Documents that they are subject to and agree to the amendment provisions contained in this Article. Owners waive their rights to any statutory remedies provided for under Title 70, Chapter 23 of the Montana Code Annotated with regard to duly adopted amendments pursuant to this Article.

11.12 Power of Attorney. Each Unit Owner hereby appoints the Declarant as his attorney-in-fact, and grants the Declarant all necessary authority so that the Declarant may record any amendment authorized by the process described herein.

11.13 Annexation. During the Declarant Control Period, Declarant may from time to time unilaterally (a) annex property to the Project, and/or (b) add Condominium Units to the Project. Annexation of property and addition of Condominium Units shall be accomplished by filing a supplement to this Declaration with the office of the Clerk and Recorder of Gallatin County, Montana. Such supplement shall not require the consent of the Owners or the Board. The supplement shall include a revised version of **Exhibit F** showing the recalculated Percentage of Interest in the Common Elements for each Condominium Unit and an updated Site Plan and Floor Plans to the extent required by the Unit Ownership Act.

11.14 Withdrawal. During the Declarant Control Period, Declarant may from time to time unilaterally amend this Declaration for the purpose of removing property then owned by Declarant or its affiliates from the coverage of this Declaration. Any property removed from this Declaration shall be subject to whatever easements, if any, are reasonably necessary for access to or operation of the Project and each of the Condominium Units. In addition, during the Declarant Control Period, Declarant may from time to time unilaterally amend this Declaration for purposes of decreasing the number of Condominium Units within the Project by removing certain Condominium Units from the coverage of this Declaration; provided that Declarant may make any such decrease only with respect to Condominium Units then owned by Declarant which have not been constructed. Any amendment pursuant to this Section shall not require the consent of the Owners or the Board. Any amendment to remove one or more Condominium Units shall include a revised

version of **Exhibit F** showing the recalculated Percentage of Interest in the Common Elements for each Condominium Unit and an updated Site Plan to the extent required by the Unit Ownership Act.

11.15 Plat Amendment. Declarant may unilaterally amend the Plat without the additional consent of any Owner or the Board; provided, however, that nothing in this paragraph allows Declarant to replat the property underlying a Condominium Unit (*i.e.*, change a boundary line or platted easement under a Condominium Unit) without the consent of the Owner of such Condominium Unit.

11.16 Merger or Consolidation. During the Declarant Control Period, Declarant may merge or consolidate the Association with a property owners association of the same form of ownership. Upon written request from Declarant during the Declarant Control Period, the Board and each Unit Owner shall execute such documents and take such actions as shall reasonably be requested by Declarant to approve and effect any such merger or consolidation.

11.17 Agreement Regarding Amendments. The Unit Owners, the Association, lienholders, mortgagees, and all others acquiring any interest in or lien on the Condominium Units, the Common Elements, or any other portion of the Project shall be bound by the rights of Declarant to amend and supplement this Declaration (and Bylaws if required) and the Plat as set forth in this Declaration, including, without limitation, in connection with any annexation of Annexed Property, removal of property from this Declaration, reduction or increase in the number of Condominium Units, completion of construction of Condominium Units, and any change in the Percentage of Interest, Site Plan, or Floor Plans in connection therewith, and their consent to such amendments and supplements is implied and agreed to by the acceptance or acquisition of any interest in or lien on the Condominium Units, the Common Elements, or any other portion of the Project. Declarant is hereby appointed the Unit Owners', Association's, lienholders', and mortgagees' agent and attorney-in-fact to execute and record such amendments, supplements, and related documents.

11.18 Recording of Amendment. Any amendment adopted pursuant to this Article must be recorded with the office of the Clerk and Recorder of Gallatin County, Montana in order to be effective. If an Owner consents to any amendment to this Declaration or the Bylaws, it will be conclusively presumed that such Owner has the authority to consent, and no contrary provision in any mortgage or contract between the Owner and a third party will affect the validity of such amendment.

ARTICLE 13 - ANNEXATION, WITHDRAWAL AND REPLATTING OF PROPERTY

13.1 Annexation Without Approval of Membership.

(a) Until December 31, 2030, Declarant may, from time to time, unilaterally subject to the provisions of this Edge 7 Condominiums Declaration all or any portion of other

property owned by Declarant (“Annexed Property”). Declarant may transfer or assign this right to annex property, provided that the transferee or assignee is the developer of at least a portion of the Property and that such transfer is memorialized in a written, recorded instrument executed by Declarant. A Supplemental Declaration shall include a revised Percentage of Interest Exhibit F showing the percentage of undivided interest in the Common Elements for each Unit Owner effective upon recording of the Supplemental Declaration.

(b) Annexation shall be accomplished by filing a Supplemental Declaration annexing the Annexed Property in the public records of Gallatin County, Montana. A Supplemental Declaration annexing property shall not require the consent of the Owners, but it shall require the consent of the owner of the Annexed Property, if other than Declarant. Any other person and/or entity with a property interest in any real property submitted to this Declaration shall not be a “Declarant” unless designated as Declarant in a recorded instrument signed by the preceding Declarant. Any annexation shall be effective upon the filing of record a Supplemental Declaration unless otherwise provided therein.

13.2 Annexation With Approval of Membership. The Association may annex real property pursuant to the provisions of this Declaration with the consent of the owner of the Annexed Property, the affirmative vote of a majority of the Owner votes of the Association represented at a meeting duly called for such purpose, the consent of the Declarant so long as Declarant owns property subject to this Declaration or which may become subject to this Declaration in accordance with Section 15.1 and the consent of the Edge 7 Condominium Owners Association Board of Directors. Annexation shall be accomplished by filing a Supplemental Declaration describing the Annexed Property in the public records of Gallatin County, Montana. Any such Supplemental Declaration shall be signed by the President and the Secretary of the Association, and by the owner of the Annexed Property. Any such annexation shall be effective upon filing unless otherwise provided therein. A Supplemental Declaration shall include a revised Percentage of Interest Exhibit F showing the percentage of undivided interest in the Common Elements for each Unit Owner effective upon recording of the Supplemental Declaration.

13.3 Withdrawal of Property. The Declarant reserves the right to amend this Declaration so long as it has a right to annex additional property pursuant to this Article and without prior notice and without the consent of any Person, for the purpose of removing property then owned by the Declarant, its affiliates, or the Association from the coverage of this Declaration, to the extent originally included in error or as a result of any changes in the Declarant’s plans for the Property, provided such withdrawal is not unequivocally contrary to the overall, uniform scheme of development for the Property. Common Areas designated as open space on any final plat for the Property, as approved by the County of Gallatin and recorded in the public records of Gallatin County, Montana, may be withdrawn only if restricted as permanent, open space upon which future inconsistent development would not be permitted.

13.4 Replatting. Declarant may unilaterally amend the plat of the Property without the additional consent of Owners. Amended plats may include, but are not limited to, the

creation of additional Units within the General Common Elements and changes to percentage ownership interest in the Common Elements. By accepting a deed to their Unit, Owners are deemed to have consented to any replatting of the Property that is consistent with the provisions of this Article and authorize Declarant to execute on their behalf any documents necessary for such replatting. Notwithstanding the above provisions, Declarant may not amend the Plat of the Property initially subject to this Declaration.

ARTICLE 14 - INTERPRETATION

14.1 Liberal Construction. The provisions of this Declaration and of the Bylaws shall be liberally construed to effectuate the purposes of this Declaration and Bylaws and to create Buildings subject to and under the provisions of the Unit Ownership Act.

14.2 Interpretation of Governing Documents. The Association, by and through its Board, shall have the exclusive right to construe and interpret the provisions of this Declaration and the other Governing Documents. In the absence of any adjudication to the contrary by a court of competent jurisdiction, the Board's construction or interpretation shall be final, conclusive and binding as to all persons and property benefitted or bound by the covenants and the provisions hereof.

ARTICLE 15 - SEVERABILITY

The provisions hereof shall be deemed independent and severable and the invalidity or partial invalidity or unenforceability of any one or more provision or any portion thereof shall not affect the validity or enforceability of the remainder of such provision or of any other provision hereof.

ARTICLE 16 - MISCELLANEOUS

16.1 Benefit. Except as otherwise provided herein, this Declaration shall be binding upon and shall inure to the benefit of the Association and each Unit Owner, and the heirs, estates, personal representatives, successors and assigns of each.

16.2 Binding Effect. The provisions of this Declaration and the Bylaws shall be construed to be covenants running with the land and shall include every Unit and shall be binding upon the Unit Owners (and any other person having an ownership interest in a Unit), their heirs, personal representatives, successors and assigns for as long as this Declaration and the Bylaws are in effect.

16.3 Service of Process. The name and address of the person to receive service of process for the Association until another designation is filed of record shall be the registered agent for the Association on file with the Montana Secretary of State.

Travis Dehaan
329 High K Street

Belgrade, MT 59714

- 16.4** **Notices.** All writings required or permitted to be given or delivered under this Declaration shall be deemed to have been given or delivered when deposited in the United States mail, postage prepaid, or by delivering it personally to an officer of the Association or Declarant or directly to a Unit Owner.
- 16.5** **Sale Disclosures.** At any time that a Person owns a majority of the Units, the Person shall provide to any purchaser the disclosure required by Montana Code Annotated § 70-23-613.
- 16.6** **Gender.** Whenever any reference herein is made to one gender, the same shall include a reference to any and all genders where the same would be appropriate; similarly, whenever a reference is made herein to the singular, a reference shall also be included to the plural where the same would be appropriate and vice versa.
- 16.7** **Conflicts.** In the event that there is any conflict or inconsistency between or among the provisions of Montana law, this Declaration, the Articles, the Bylaws and the Rules and Regulations, the provisions of Montana law, this Declaration, the Articles, the Bylaws and the Rules and Regulations (in that order) shall prevail.

REMAINDER OF PAGE INTENTIONALLY LEFT BLANK

IN WITNESS WHEREOF, the Declarant has caused this Declaration to be made and executed according to the provisions of the Montana Unit Ownership Act, Section 70-23-101, et seq., MCA (2019).

DECLARANT:

Dehaan Construction, Inc.

BY: *[Signature]*
President, Darrel DeHaan

State of Montana)
: ss.
County of Gallatin)

On this 9th day of November, 2020, before me, a Notary Public in and for said State, personally appeared Darrel DeHaan, **President of Dehaan Construction, Inc.**, and acknowledged to me that he executed the same on behalf of the limited liability company pursuant to the power and authority vested in him.

IN WITNESS WHEREOF, I have hereunto set my hand and affixed my Notarial seal the day and year written above.

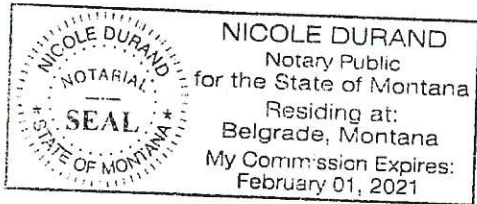

[Signature]
Nicole Durand (print name)
Notary Public for the State of Montana
Residing at Belgrade, Montana.
My commission expires: 2-1-21

EXHIBIT A-1 – LEGAL DESCRIPTION OF PROPERTY

The following described real property located in Gallatin County, Montana:

All that part of Block 15 of Belleview Addition to the Town of Belgrade, Montana, laying South of Custer Avenue or the extension of said Custer Avenue, according to the official plat of Belleview Addition to the Town of Belgrade, Montana, according to the official plat on file and of record in the office of the County Clerk and Recorder of Gallatin County, Montana. EXCEPTING THEREFROM 50 feet off the entire North end of all that part of Block 15 of the Belleview Addition to the Town of Belgrade, lying south of Custer Avenue or the extension of said Custer Avenue, according to the official plat of Belleview Addition to the Town of Belgrade, Montana, according to the official plat on file and of record in the office of the County Clerk and Recorder of Gallatin County, Montana. [Deed Reference: Film 9, page 1587]

TOGETHER WITH that portion of vacated Cascade Avenue located in Block 15 of Belleview Addition which attached to said lot by operation of law pursuant to Resolution No. 467 dated November 7, 1977 and recorded June 26, 1978 in Film 44, page 1006, records of Gallatin County, Montana.

EXHIBIT A-2 – GALLATIN COUNTY EXEMPTION CERTIFICATE



CERTIFICATE OF EXEMPTION FROM SUBDIVISION REVIEW

I, Jason Karp, Planner for the Belgrade City-County Planning Office, do hereby certify that the Declaration for the Edge 7 Condominium, submitted June 29, 2020, by DeHaan Construction pursuant to Title 70, Chapter 23, Montana Code Annotated, is exempt from review under the Montana Subdivision and Platting Act pursuant to Section 76-3-203, MCA.

The condominiums are to be located on the following described real property:

Lot 3, Block 15, Belleview Addition Subdivision, Plat D-17-X, located in the NW ¼ of Section 12, T1S, R4E, P.M.M. Gallatin County, Montana, according to the official plat thereof on file and of record in the office the County Clerk and Recorder of Gallatin County, Montana. The addresses of the Condominiums are 609 Oregon Street, Units A and B, 611 Oregon St, Units A,B, and C, and 704 Minnesota Units A and B, Belgrade, MT, 59714.

The Declaration is exempt because the condominiums are to be constructed on land that: (1) was expressly contemplated for the construction of condominiums or; (2) the condominium proposal is in conformance with applicable local zoning regulations.

DATED this 10th Day of July, 2020.

Jason Karp, Belgrade City-County Planning Director

EXHIBIT B – CERTIFICATE OF NAME

EXHIBIT B – CERTIFICATE OF NAME

The undersigned being the duly authorized agent of the Department of Revenue of the State of Montana within the County of Gallatin, herewith executes the following certificate relating to the **EDGE 7 CONDOMINIUMS** situated as follows:

All that part of Block 15 of Belleview Addition to the Town of Belgrade, Montana, laying South of Custer Avenue or the extension of said Custer Avenue, according to the official plat of Belleview Addition to the Town of Belgrade, Montana, according to the official plat on file and of record in the office of the County Clerk and Recorder of Gallatin County, Montana. EXCEPTING THEREFROM 50 feet off the entire North end of all that part of Block 15 of the Belleview Addition to the Town of Belgrade, lying south of Custer Avenue or the extension of said Custer Avenue, according to the official plat of Belleview Addition to the Town of Belgrade, Montana, according to the official plat on file and of record in the office of the County Clerk and Recorder of Gallatin County, Montana. [Deed Reference: Film 9, page 1587]

TOGETHER WITH that portion of vacated Cascade Avenue located in Block 15 of Belleview Addition which attached to said lot by operation of law pursuant to Resolution No. 467 dated November 7, 1977 and recorded June 26, 1978 in Film 44, page 1006, records of Gallatin County, Montana.

- 1) That the name the **EDGE 7 CONDOMINIUMS** is not the same as, similar to or pronounced the same as a word in the name of any other property or subdivision within Gallatin County, except for the word "Condominium(s)", and
- 2) All taxes and assessments due and payable for the said **EDGE 7 CONDOMINIUMS** have been paid to date.

Dated: 12/9/2020
By: Maureen Horton
Title: Data Control Tech

EXHIBIT C – SITE PLAN

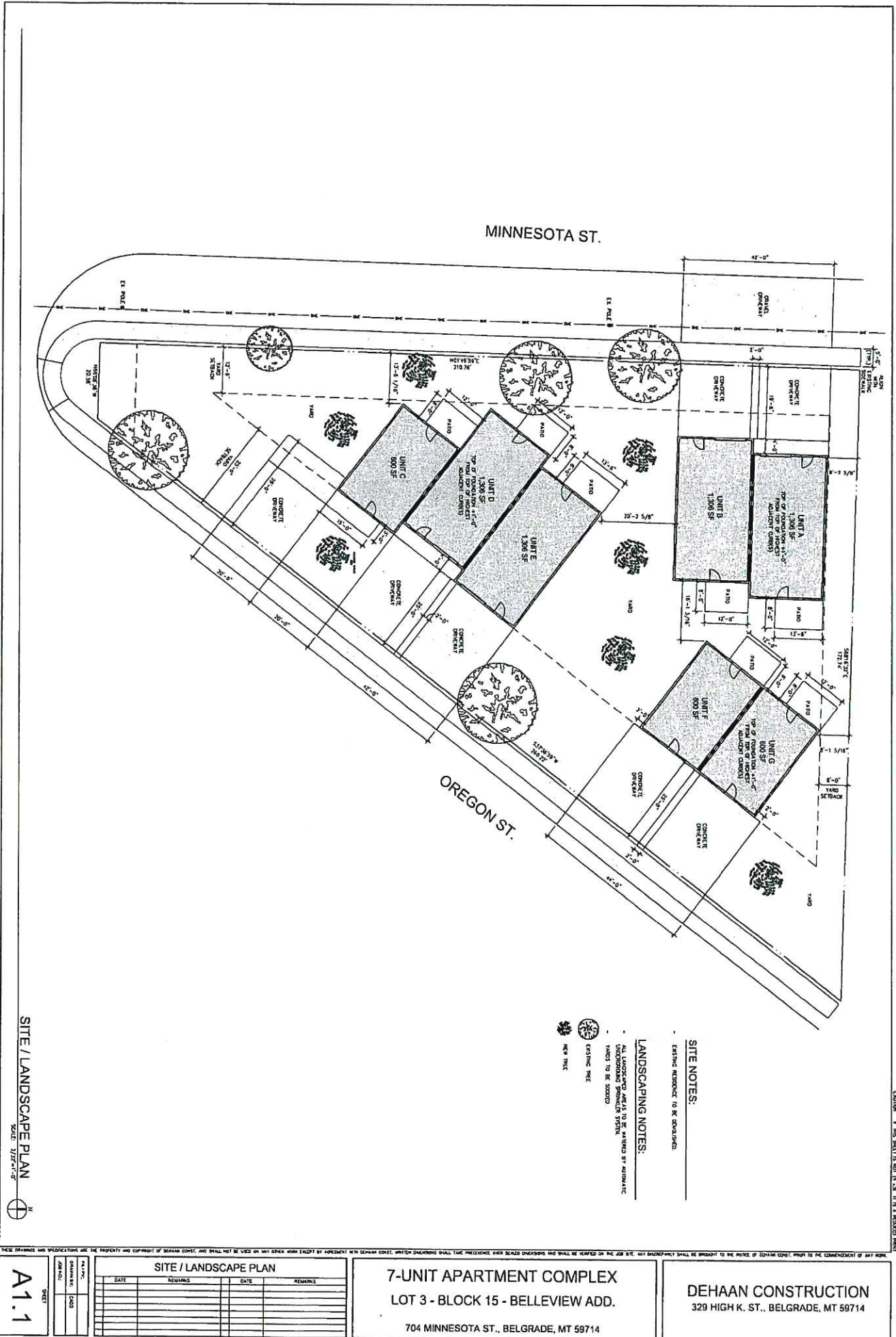

SITE / LANDSCAPE PLAN
SCALE: 1/8" = 1' - 0"

<p>SITE / LANDSCAPE PLAN</p> <table border="1"> <thead> <tr> <th>DATE</th> <th>REVISIONS</th> <th>DATE</th> <th>REVISIONS</th> </tr> </thead> <tbody> <tr> <td> </td> <td> </td> <td> </td> <td> </td> </tr> <tr> <td> </td> <td> </td> <td> </td> <td> </td> </tr> <tr> <td> </td> <td> </td> <td> </td> <td> </td> </tr> <tr> <td> </td> <td> </td> <td> </td> <td> </td> </tr> </tbody> </table>		DATE	REVISIONS	DATE	REVISIONS																	<p>7-UNIT APARTMENT COMPLEX LOT 3 - BLOCK 15 - BELLEVUE ADD.</p> <p>704 MINNESOTA ST., BELGRADE, MT 59714</p>	<p>DEHAAN CONSTRUCTION 329 HIGH K. ST., BELGRADE, MT 59714</p>
DATE	REVISIONS	DATE	REVISIONS																				

A1.1

EXHIBIT D – CONSTRUCTION MATERIALS

The principal materials of each Building as constructed are as follows:

- Wood for the framing, structural, finish work,
- Cement Board Siding
- cedar accents on the exterior wall surfaces;
- Sheetrock for the interior walls and ceilings;
- Carpet, wood or vinyl for floors;
- Concrete for foundations, slabs (including garage floor);
- Asphalt shingles on the roof; and
- Concrete patios.

EXHIBIT E – CERTIFICATE OF FLOOR PLANS

Exhibit E

CERTIFICATE OF FLOOR PLANS

The undersigned, being a duly licensed engineer and land surveyor in the State of Montana, herewith certifies the following:

That pursuant to the provisions of 70-23-306(2) MCA, the site plan and floor plans for Units 609A, 609B, 611A, 611B, 611C, 704A and 704B, of the Edge 7 Condominium, located on:

That part of Block 15, BELLEVIEW ADDITION TO BELGRADE, [Plat J-633], as described in Warranty Deed recorded as Document No. 2677945, and located in the NW 1/4 of Section 12, Township 1 South, Range 4 East of P.M.M., Gallatin County, Montana.

accurately depict the plans filed with and approved by the city and/or county officials having jurisdiction to issue building permits, and as duly filed with the Declaration and Bylaws thereof, fully and accurately depict the layout, location, unit designation, areas and dimensions of each unit as built and the common areas to which each has access.

Dated OCT. 29, 2020



Mark A. Chandler, P.E., P.L.S.
Professional Engineer and Land Surveyor
Montana License No. 9518-ES



EXHIBIT F – UNIT DESIGNATION AND PERCENTAGE OF INTEREST

Unit Designation on Site Plan	Address	Percentage of Interest
Unit 611C	611C Oregon Street Belgrade, MT 59714	7.04%
Unit 611B	611B Oregon Street Belgrade, MT 59714	19.72%
Unit 611A	611A Oregon Street Belgrade, MT 59714	19.72%
Unit 609B	609B Oregon Street Belgrade, MT 59714	7.04%
Unit 609A	609A Oregon Street Belgrade, MT 59714	7.04%
Unit 704A	704A Minnesota Street Belgrade, MT 59714	19.72%
Unit 704B	704B Minnesota Street Belgrade, MT 59714	19.72%
		100%

EXHIBIT G – FLOOR PLANS

LEGAL DESCRIPTION
 A PORTION OF BLOCK 15, BELLEVUE
 ADDITION [PLAT J-6533] LOCATED IN NW
 1/4, SEC. 12, T. 1 S., R. 4 E. OF P.M.M.,
 BELGRADE, MONTANA

EXHIBIT G
FIRST FLOOR PLAN - TRIPLEX - BUILDING 611
EDGE 7 CONDOMINIUM

MEASURED: NM 10/23/2020
 JG 10/23/2020

- NOTES**
1. ALL SIDEWALKS, STOOPS, DRIVEWAYS, PATIOS, PORCHES, DECKS AND ATTICS ARE LIMITED COMMON ELEMENTS ALLOCATED TO UNITS THEY ARE ADJACENT TO.
 2. THE EXTERIOR SURFACE OF THE FLOOR PLANS ARE MEASURED TO WALLS, AND TO THE CENTERLINE OF COMMON WALLS. INTERIOR STAIRWAYS ARE INCLUDED IN THE FLOOR AREA OF THE LOWER LEVEL ONLY. THIS IS DONE TO MATCH THE ASSESSOR'S OFFICE FLOOR AREAS AS THEY CALCULATE THEM. THE ACTUAL UNIT BOUNDARIES ARE AS DEFINED IN THE DECLARATION OF CONDOMINIUM.

FLOOR AREA TABULATION - EDGE 7 CONDOMINIUM

UNIT	1st FLOOR	2nd FLOOR	TOTAL
UNIT 609A	600 SF		600 SF
UNIT 609B	600 SF		600 SF
UNIT 611A	840 SF	840 SF	1,680 SF
UNIT 611B	840 SF	840 SF	1,680 SF
UNIT 611C	600 SF		600 SF
UNIT 704A	840 SF	840 SF	1,680 SF
UNIT 704B	840 SF	840 SF	1,680 SF
TOTAL	5,160 SF	3,360 SF	8,520 SF

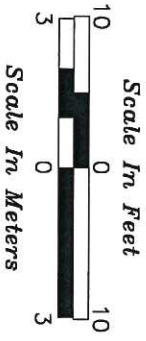

Engineering and Surveying Inc.
 1091 Stoneridge Drive • Bozeman, MT 59718
 Phone (406) 587-1115 • Fax (406) 587-9788
 www.chenghs.com • info@chenghs.com

Sheet 1 of 5

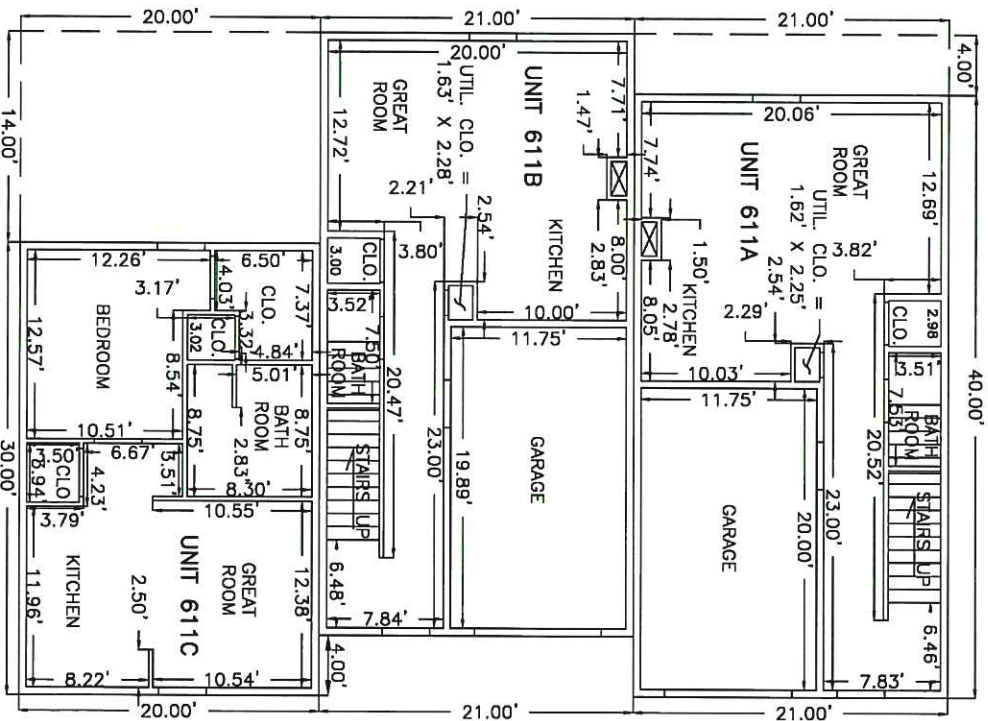

* DRYWALL WAS INCOMPLETE AT THE TIME OF THE MEASURE-UP

LEGAL DESCRIPTION

A PORTION OF BLOCK 15, BELLEVUE ADDITION [PLAT J-633] LOCATED IN NW 1/4, SEC. 12, T. 1 S., R. 4 E. OF P.M.M., BELGRADE, MONTANA

EXHIBIT G
SECOND FLOOR PLAN - TRIPLEX - BUILDING 611
EDGE 7 CONDOMINIUM

MEASURED: NM 10/23/2020
 JG 10/23/2020

NOTES

1. ALL SIDEWALKS, STOOPS, DRIVEWAYS, PATIOS, PORCHES, DECKS AND ATTICS ARE LIMITED COMMON ELEMENTS ALLOCATED TO UNITS THEY ARE ADJACENT TO.
2. THE EXTERIOR SURFACE OF THE FLOOR PLANS ARE MEASURED TO WALLS, AND TO THE CENTERLINE OF COMMON WALLS. INTERIOR STAIRWAYS ARE INCLUDED IN THE FLOOR AREA OF THE LOWER LEVEL ONLY. THIS IS DONE TO MATCH THE ASSESSOR'S OFFICE FLOOR AREAS AS THEY CALCULATE THEM. THE ACTUAL UNIT BOUNDARIES ARE AS DEFINED IN THE DECLARATION OF CONDOMINIUM.

FLOOR AREA TABULATION - EDGE 7 CONDOMINIUM

UNIT	1st FLOOR	2nd FLOOR	TOTAL
UNIT 609A	600 SF		600 SF
UNIT 609B	600 SF		600 SF
UNIT 611A	840 SF	840 SF	1,680 SF
UNIT 611B	840 SF	840 SF	1,680 SF
UNIT 611C	600 SF		600 SF
UNIT 704A	840 SF	840 SF	1,680 SF
UNIT 704B	840 SF	840 SF	1,680 SF
TOTAL	5,160 SF	3,360 SF	8,520 SF

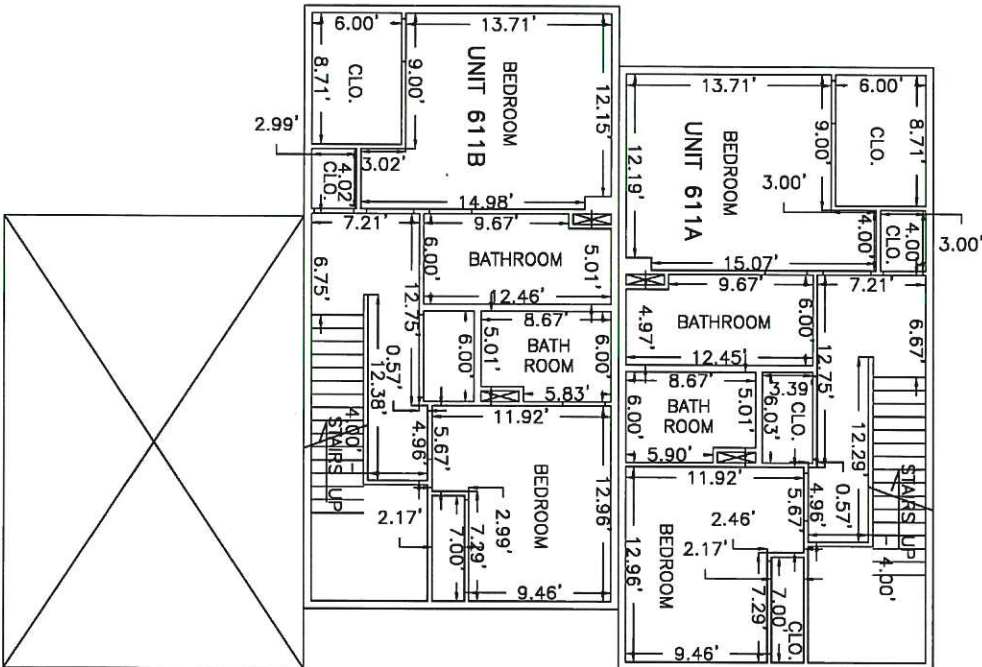
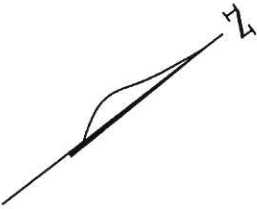
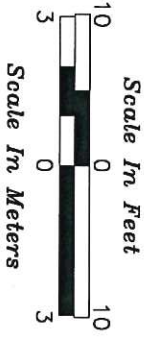

C&H
 Engineering and Surveying Inc.
 1091 Spanridge Drive • Bozeman, MT 59718
 Phone (406) 587-1115 • Fax (406) 587-9789
 www.chengineers.com • info@chengineers.com

LEGAL DESCRIPTION

A PORTION OF BLOCK 15, BELLEVUE
 ADDITION [PLAT J-633] LOCATED IN NW
 1/4, SEC. 12, T. 1 S., R. 4 E. OF P.M.M.,
 BELGRADE, MONTANA

EXHIBIT G
 FIRST FLOOR PLAN - 2 STORY DUPLEX - BUILDING 704
 EDGE 7 CONDOMINIUM

MEASURED: NM 10/23/2020
 JG 10/23/2020

NOTES

1. ALL SIDEWALKS, STOOPS, DRIVEWAYS, PATIOS, PORCHES, DECKS AND ATTICS ARE LIMITED COMMON ELEMENTS ALLOCATED TO UNITS THEY ARE ADJACENT TO.
2. THE EXTERIOR SURFACE OF THE FLOOR PLANS ARE MEASURED TO WALLS, AND TO THE CENTERLINE OF COMMON WALLS. INTERIOR STAIRWAYS ARE INCLUDED IN THE FLOOR AREA OF THE LOWER LEVEL ONLY. THIS IS DONE TO MATCH THE ASSESSOR'S OFFICE FLOOR AREAS AS THEY CALCULATE THEM. THE ACTUAL UNIT BOUNDARIES ARE AS DEFINED IN THE DECLARATION OF CONDOMINIUM.

FLOOR AREA TABULATION - EDGE 7 CONDOMINIUM

UNIT	1st FLOOR	2nd FLOOR	TOTAL
UNIT 609A	600 SF	600 SF	600 SF
UNIT 609B	840 SF	840 SF	1,680 SF
UNIT 611A	840 SF	840 SF	1,680 SF
UNIT 611B	600 SF	600 SF	600 SF
UNIT 611C	840 SF	840 SF	1,680 SF
UNIT 704A	840 SF	840 SF	1,680 SF
UNIT 704B	840 SF	840 SF	1,680 SF
TOTAL	5,160 SF	3,360 SF	8,520 SF

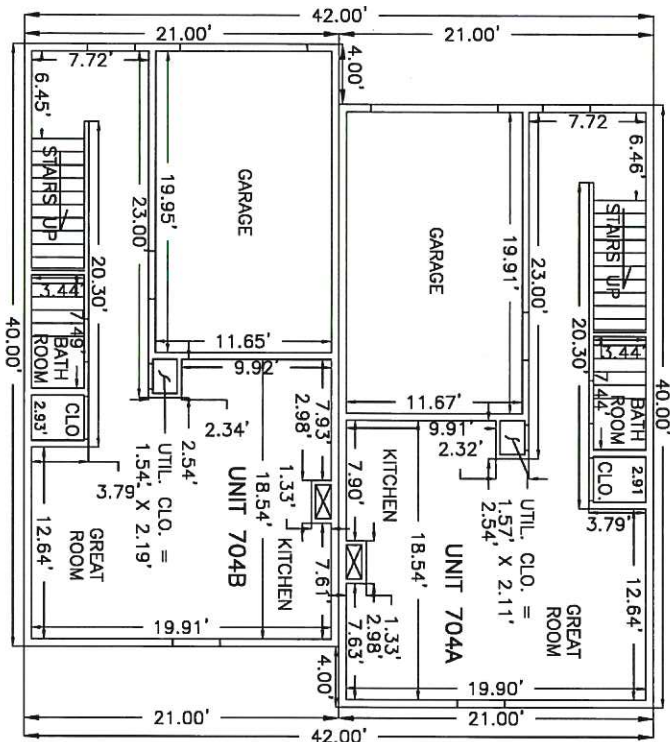
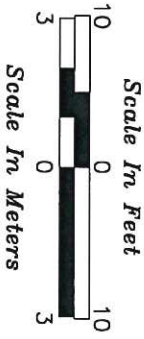

Engineering and Surveying Inc.
 1091 Scenic Drive • Bozeman, MT 59718
 Phone (406) 587-1115 • Fax (406) 587-9788
 www.chenginers.com • info@chenginers.com

Sheet 3 of 5

LEGAL DESCRIPTION
 A PORTION OF BLOCK 15, BELLEVUE
 ADDITION [PLAT J-653] LOCATED IN NW
 1/4, SEC. 12, T. 1 S., R. 4 E. OF P.M.M.,
 BELGRADE, MONTANA

EXHIBIT G
SECOND FLOOR PLAN - 2 STORY DUPLEX - BUILDING 704
EDGE 7 CONDOMINIUM

MEASURED: NM 10/23/2020
 JG 10/23/2020

NOTES

1. ALL SIDEWALKS, STOOPS, DRIVEWAYS, PATIOS, PORCHES, DECKS AND ATTICS ARE LIMITED COMMON ELEMENTS ALLOCATED TO UNITS THEY ARE ADJACENT TO.
2. UNIT AREAS SHOWN ON THE FLOOR PLANS ARE MEASURED TO THE EXTERIOR SURFACE OF THE STUD WALLS ON EXTERIOR WALLS, AND TO THE CENTERLINE OF COMMON WALLS. INTERIOR STAIRWAYS ARE INCLUDED IN THE FLOOR AREA OF THE LOWER LEVEL ONLY. THIS IS DONE TO MATCH THE ASSESSOR'S OFFICE FLOOR AREAS AS THEY CALCULATE THEM. THE ACTUAL UNIT BOUNDARIES ARE AS DEFINED IN THE DECLARATION OF CONDOMINIUM.

FLOOR AREA TABULATION - EDGE 7 CONDOMINIUM

	1st FLOOR	2nd FLOOR	TOTAL
UNIT 609A	600 SF		600 SF
UNIT 609B	600 SF		600 SF
UNIT 611A	840 SF	840 SF	1,680 SF
UNIT 611B	840 SF	840 SF	1,680 SF
UNIT 611C	600 SF		600 SF
UNIT 704A	840 SF	840 SF	1,680 SF
UNIT 704B	840 SF	840 SF	1,680 SF
TOTAL	5,160 SF	3,360 SF	8,520 SF

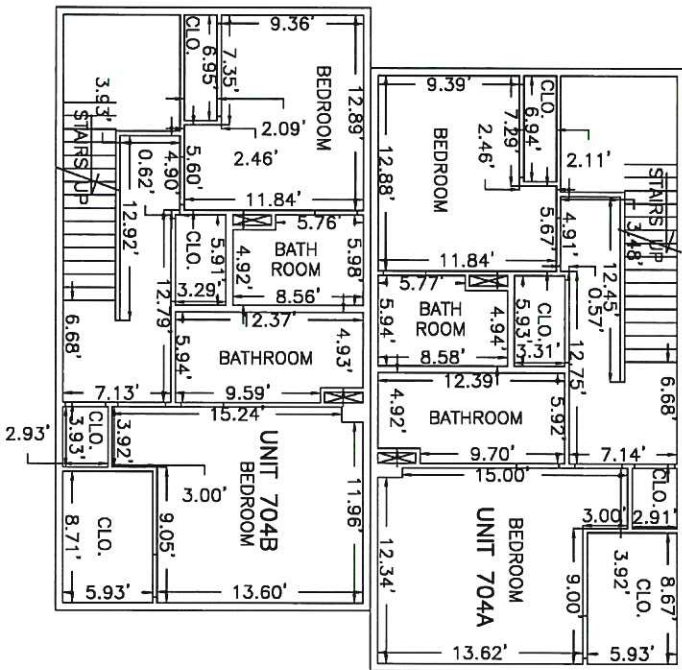
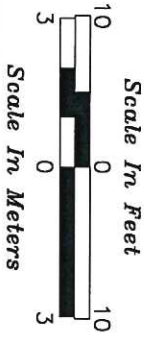

CEH
 Engineering and Surveying Inc.
 1091 Spangler Drive • Bozeman, MT 59718
 Phone (406) 587-1115 • Fax (406) 587-9769
 www.chenginers.com • info@chenginers.com

Sheet 4 of 5

LEGAL DESCRIPTION

A PORTION OF BLOCK 15, BELLEVUE
 ADDITION [PLAT J-633] LOCATED IN NW
 1/4, SEC. 12, T. 1 S., R. 4 E. OF P.M.M.,
 BELGRADE, MONTANA

EXHIBIT G
FIRST FLOOR PLAN - 1 STORY DUPLEX - BUILDING 609
EDGE 7 CONDOMINIUM

MEASURED: NM 10/23/2020
 JG 10/23/2020

NOTES

1. ALL SIDEWALKS, STOOPS, DRIVEWAYS, PATIOS, PORCHES, DECKS AND ATTICS ARE LIMITED COMMON ELEMENTS ALLOCATED TO UNITS THEY ARE ADJACENT TO.
2. UNIT AREAS SHOWN ON THE FLOOR PLANS ARE MEASURED TO THE EXTERIOR SURFACE OF THE STUD WALLS ON EXTERIOR WALLS, AND TO THE CENTERLINE OF COMMON WALLS. INTERIOR STAIRWAYS ARE INCLUDED IN THE FLOOR AREA OF THE LOWER LEVEL ONLY. THIS IS DONE TO MATCH THE ASSESSOR'S OFFICE FLOOR AREAS AS THEY CALCULATE THEM. THE ACTUAL UNIT BOUNDARIES ARE AS DEFINED IN THE DECLARATION OF CONDOMINIUM.

FLOOR AREA TABULATION - EDGE 7 CONDOMINIUM

	1st FLOOR	2nd FLOOR	TOTAL
UNIT 609A	600 SF	600 SF	600 SF
UNIT 609B	600 SF	600 SF	600 SF
UNIT 611A	840 SF	840 SF	1,680 SF
UNIT 611B	840 SF	840 SF	1,680 SF
UNIT 611C	600 SF	600 SF	600 SF
UNIT 704A	840 SF	840 SF	1,680 SF
UNIT 704B	840 SF	840 SF	1,680 SF
TOTAL	5,160 SF	3,360 SF	8,520 SF

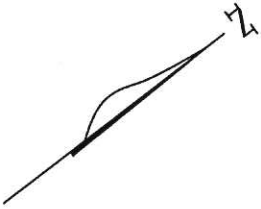
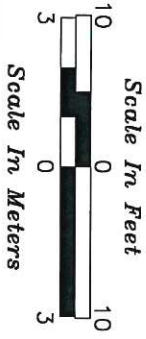

Engineering and Surveying Inc.
 1091 Stoneridge Drive • Bozeman, MT 59718
 Phone (406) 587-1115 • Fax (406) 587-5768
 www.changinengineers.com • info@changinengineers.com

Sheet 5 of 5

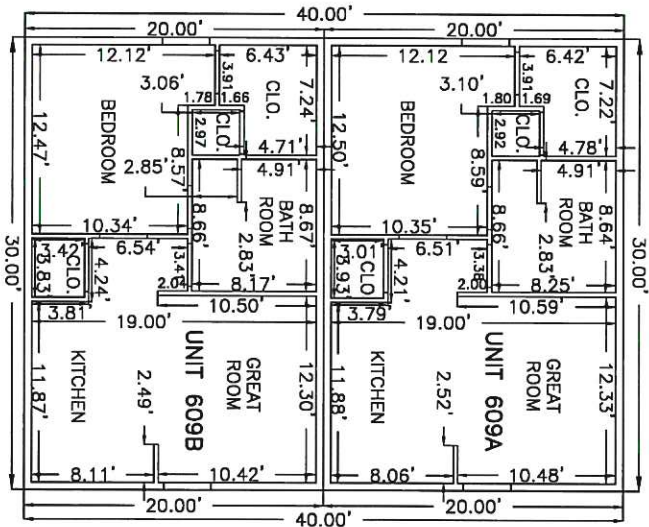

EXHIBIT H - MUNICIPAL FACILITIES EXCLUSION



December 3, 2020

Griffith & Cummings PC
PO Box 160748
Big Sky MT 59716

RE: Edge 7 Condominiums
Municipal Facilities Exclusion
EQ# 21-1559
City of Bozeman
Gallatin County

Dear Sirs;

This is to certify that the information and fees received by the Department of Environmental Quality relating to this subdivision are in compliance with 76-4-127, MCA. Under 76-4-125(1)(d), MCA, this subdivision is not subject to review, and the Declaration can be filed with the county clerk and recorder.

Plans and specifications must be submitted when extensions of municipal facilities for the supply of water or disposal of sewage are proposed 76-4-131. Construction of water or sewer extensions prior to DEQ, Public Water Supply Section's approval is prohibited, and is subject to penalty as prescribed in Title 75, Chapter 6 and Title 76, Chapter 4.

Edge 7 Condominiums Municipal Facilities Exclusion will consist of Seven Units.

Sincerely,

Ashley Kroon
Department of Environmental Quality
Engineering Bureau
Public Water & Subdivision Review
(406) 461-9844
email akroon@mt.gov

cc: City Engineer
County Sanitarian
Owner
file

After recording, return to:

Griffith & Cummings, PC
P.O. Box 160748
Big Sky, Montana 59716

**BYLAWS
OF
EDGE 7 CONDOMINIUM OWNER'S ASSOCIATION, INC.**

ARTICLE 1 - GENERAL PROVISIONS

- 1.1 **Legal Description.** These Bylaws ("Bylaws") apply to Edge 7 Condominium Owner's Association, Inc. ("Association"), which governs the property more particularly described on Exhibit A, together with any property added to the Declaration (as defined in Section 2.2 below), as such may be amended, restated or finalized from time to time.
- 1.2 **Adoption.** These Bylaws were adopted by the Declarant of the Condominiums and the Board of Directors of the Corporation (the "Board") as these are the first bylaws adopted for the Association.

ARTICLE 2 - DEFINITIONS AND GOVERNANCE

- 2.1 **Definitions.** Unless otherwise defined herein, all terms used in these Bylaws shall have the meanings set forth in the Declaration, as such may be amended, restated or finalized from time to time. The definitions contained in the Declaration are incorporated by reference herein.
- 2.2 **Declaration.** "Declaration" shall mean and refer to the Declaration for the Edge 7 Condominiums, recorded on the ____ day of _____, 20____, as Document No. _____, records of Gallatin County, Montana, as such may be amended, restated or finalized from time to time.

ARTICLE 3 - MEMBERSHIP VOTING RIGHTS

- 3.1 Membership.** The members of the Association (the “Members”) shall be the Unit Owners as set forth in the Declaration and membership in the Association shall transfer in accordance with and otherwise be subject to the Declaration. The Members shall be subject to and comply with all Governing Documents.
- 3.2 Voting Rights.** Voting shall be based on the Percentage of Interest as set for the in the Declaration. If ownership of any Unit is vested in more than one person, then the vote for such Unit shall be exercised as the co-owners of such Unit decide among themselves and advise the Secretary of the Association in writing prior to any meeting or vote. Voting rights of an Owner that is not a natural person may be exercised by any officer, director, partner, trustee, member, manager, or other individual designated from time to time in a written instrument describing and certifying the authority of such person provided to the Secretary of the Association in writing prior to any meeting or vote. In a multiple interest Owner situation or in the situation of an Owner that is not a natural person, absent written advice to the Secretary of the Association, if more than one person seeks to exercise the vote the voting privilege with respect to the Unit shall be suspended. Except as otherwise expressly required by law, only Members in good standing (not delinquent in the payment of dues or other fees owed to the Association and not in violation of any provision of these Bylaws, the Declaration or any other Governing Documents) are entitled to vote. Neither the Association nor Declarant shall have any obligation to confirm, as among such multiple interest Owners or with respect to an Owner which is not a natural person, which of the persons has the right to exercise a vote. The written advice to the Secretary of the Association shall state which person has authority to act on behalf of the Unit Owner and include that person’s name, mailing and physical address, telephone number and email address. The Association may rely on such notice until such notice is updated by a Unit Owner.
- 3.3 Annual Meeting.** The annual meeting of the Members shall be held each year at a time and place determined by the Board of Directors, or such month thereafter that is determined reasonably practical, at a date, time and place to be set by the Board. The Members shall elect a Board and transact any other business that may legally come before the meeting.
- 3.4 Special Meetings.** Special meetings of the Members may be called by the President of the Association, the Board, or the holders of not less than five percent (5%) of the Percentage of Interest entitled to vote by written demand for a meeting signed and dated by such Members, describing the purpose for which the meeting is to be held, and delivered to any officer of the Association. Only matters within the purpose(s) described in the notice for a special meeting of the Members may be conducted at the special meeting.
- 3.5 Method of Calling Meetings.** Written or printed notice stating the place, date and time of the meeting, and, in case of a special meeting, the purpose or purposes for

which the meeting is called, shall be delivered not less than ten (10) nor more than sixty (60) days before the date of the meeting, either personally, electronically, by facsimile or by mail, by or at the direction of the President, Secretary, and Treasurer, or the officer or persons calling the meeting, to each Member of record entitled to vote at such meeting. If mailed, such notice shall be deemed to be given three (3) days after the date when deposited in the United States mail, with postage prepaid, addressed to the Member at his, her or its address as it appears on the records of the Association, or at his, her or its last known address. If notice is given electronically, such notice shall be deemed to be delivered when sent. If notice is delivered by facsimile, such notice shall be deemed to be delivered upon facsimile confirmation.

- 3.6 Quorum.** Members representing a majority of the Units either in person or by proxy, shall constitute a quorum at a meeting of Members. When a quorum is present or represented at any meeting, the vote of a majority of the Members present in person or represented by proxy, shall decide any question brought before such meeting, unless the question is one upon which, by express provisions of the Declaration, a different vote is required, in which case such express provision shall govern and control the decision of such question. If less than a quorum is present at a meeting, a majority of the Members entitled to vote and present at such meeting may adjourn the meeting without further notice until a quorum is present and represented.
- 3.7 Proxies.** At all meetings of Members, each Member may vote in person or by proxy. All proxies shall be in writing and filed with the Secretary of the Association before the appointed time of each meeting. Every proxy shall be revocable and shall automatically cease upon conveyance by the Member of his, her or its Unit, or upon receipt of written notice by the Secretary of the Association of the death or judicially declared incompetence of a Member, or upon the expiration of eleven (11) months from the date of the proxy. The proxy shall identify the person or persons authorized to exercise the proxy and the length of time it will be valid. If the Member specifies a choice in his, her or its proxy, the vote shall be cast in accordance with that choice. In addition, voting by proxy shall comply with any other applicable requirements of Mont. Code Ann. § 35-2-539.
- 3.8 Electronic Participation.** Members may participate in a meeting of the Members by means of a conference telephone call or similar communication equipment through which all persons participating in the meeting can hear each other at the same time. Participation in this manner constitutes presence in person at a meeting.

ARTICLE 4 - BOARD OF DIRECTORS

- 4.1 General Powers.** The business and affairs of the Association shall be managed by its Board. The Board shall in all cases act as a board, and they may adopt such rules and regulations for the conduct of their meetings, the management of the

Association, and the use of the Common Elements as they may deem proper, not inconsistent with these Bylaws, the Declaration and the laws of the State of Montana. The Board shall also have the rights, duties and obligations specified in the Declaration. The Board may employ a manager or management agent (a "Manager"), to be compensated in an amount established by the Board, to perform such duties and services as the Board shall authorize. The Board may also retain accountants, lawyers and other professionals and advisors as it deems necessary or advisable. The Board may employ personnel or contract for the maintenance, upkeep and repair of the Common Elements or other property or equipment owned or provided for the use of the Association.

- 4.2 Number and Qualification.** The Association shall have not less than three (3) directors ("Directors") who shall constitute the Board as the governing body of the Association. The number of Directors may be increased or decreased, but not fewer than three (3), from time to time by amendment of these Bylaws. Unless vacated sooner, each Director shall hold office until the Director's term expires and a successor is elected or until such Director's earlier death, resignation or removal. The election of the Board shall be conducted at the annual meeting of the Members. At such annual meeting, the Members in good standing shall elect the Board. An elected Director must be a Member (or representative of a Member) in good standing. At such election, the Members or their proxies may cast their vote(s) for each vacancy. The persons receiving the largest number of votes shall be elected. There shall be no cumulative voting. Voting for Directors or for their removal may be by written ballot.
- 4.3 Election.** The election of the Board shall be conducted at the annual meeting of the Members.
- 4.4 Terms.** Directors shall serve staggered terms of three (3) years. To achieve staggered terms, the term of one (1) Director shall be for three (3) years, the term of one (1) Director shall be for two (2) years, and the term of one (1) Director shall be for one (1) year, and thereafter one Director shall be elected each year and all such subsequently elected Directors shall serve terms of three (3) years. Unless vacated sooner, each Director shall hold office until the Director's term expires and a successor is elected.
- 4.5 Annual Meetings.** The annual meeting of the Board shall be held each fiscal year beginning on the first day of January of each calendar year through the 31st day of December in that same calendar year at a date, time and place designated by the Board.
- 4.6 Special Meetings.** Special meetings of the Board may be called by or at the written request of the President of the Association or any of the Directors. The person or persons authorized to call other meetings of the Board may fix the place and time for the meeting.

- 4.7 **Notice.** Notice of any annual or other meeting of the Board shall be given at least two (2) days prior to the scheduled meeting, by written notice delivered personally, electronically or by facsimile transmission or mailed to each Director at the address for such person on the books of the corporation. If mailed, such notice shall be deemed to be delivered three (3) days after it was deposited in the United States mail, with proper postage pre-paid. If notice is given electronically, such notice shall be deemed to be delivered when sent. If notice be given by facsimile, such notice shall be deemed to be delivered upon facsimile confirmation. The participation of a Director at a meeting shall constitute a waiver of notice of such meeting, except where a Director attends a meeting for the express purpose of objecting to the transaction of any business because the meeting is not lawfully called or convened and such Director must file a written dissent with the person acting as Secretary of the meeting before the adjournment or immediately after adjournment of the meeting.
- 4.8 **Quorum.** At any meeting of the Board, a majority of the total Directors shall constitute a quorum.
- 4.9 **Manner of Acting.** Each Director shall have one vote. The affirmative vote of a majority of the Directors present at a meeting at which a quorum is present shall constitute the act of the Board. However, the affirmative vote of a single Director present at a meeting at which a quorum is present shall not be the act of the Directors unless a majority of the Directors in office vote in favor of authorizing such.
- 4.10 **Action without Meeting.** Action required or permitted to be taken at a Board meeting may be taken without a meeting if the action is approved by all members of the Board. The action must be evidenced by written consents (delivered personally, electronically, by facsimile or by mail) signed by all Directors.
- 4.11 **Attendance.** All Directors may participate in a regular or special meeting through the use of any means of communication by which all Directors participating may simultaneously hear each other during the meeting. A Director participating in a meeting by this means is considered to be present in person at the meeting.
- 4.12 **Removal of Directors.** The Members may remove a Director, with or without cause, by casting the votes of the Percentage of Interest that would be sufficient to elect the Director. A Director elected by the Members may be removed by the Members only at a meeting called for the purpose of removing the Director. The meeting notice must state that the purpose or one of the purposes of the meeting is removal of the Director.
- 4.13 **Resignation.** A Director may resign at any time by giving written notice to the Board, the President, the Secretary or the Treasurer of the Association. Unless otherwise specified in the notice, the resignation shall take effect at the date specified in the notice or if such date is not specified, then upon receipt thereof by

the Board or such officer. The acceptance of the resignation shall not be necessary to make it effective.

- 4.14 **Vacancies.** If a Director dies or resigns, the vacancy shall be filled by the remaining Board at a duly held meeting, or by the sole remaining Director; provided, however, a vacancy created by the removal of a Director by the Members can be filled only by election by the Members. A successor Director shall serve for the unexpired term of his or her predecessor.
- 4.15 **Compensation.** No Director shall receive compensation for any service rendered to the Association as a Director. However, any Director may be reimbursed for his or her actual expenses, if reasonable, incurred in the performance of his or her duties as a Director.
- 4.16 **Indemnification.** The Association shall indemnify and advance expenses to any present or former Director or officer of the Association to the fullest extent authorized under Mont. Code Ann. §§ 35-2-446 through 35-2-452, as such may be amended, or any successor statutes. The rights to indemnification and advances set forth in this Section 4.16 shall be contract rights, and any amendment to or repeal of this Section 4.16 (or any provision hereof) shall not adversely affect any right to indemnification or advancement with respect to acts or omissions of an indemnitee occurring prior to such amendment or repeal (regardless of whether the proceeding relating to such acts or omissions is commenced before or after such amendment or repeal).

ARTICLE 5 - OFFICERS

- 5.1 **Enumeration of Officers.** The officers of the Association shall be President, Secretary and Treasurer, each of whom shall be appointed by the Board. Such other officers and assistant officers as may be deemed necessary may be appointed by the Board.
- 5.2 **Term of Office.** Each officer shall hold office until the earlier of his or her successor being duly appointed, or his or her death, resignation or removal.
- 5.3 **Resignation and Removal.** Any officer or agent appointed by the Board may be removed by the Board at any time, with or without cause. Any officer may resign at any time by giving written notice to the Board. Such resignation shall take effect at the date of receipt of such notice or at any later time specified therein, and unless otherwise specified therein, the acceptance of such resignation shall not be necessary to make it effective.
- 5.4 **Vacancies.** A vacancy in any office may be filled by the Board. The officer appointed to such vacancy shall serve the remainder of the term of the officer he or she replaces.

- 5.5 **President.** The President shall be the principal executive officer of the Association and, subject to the control of the Board, shall in general supervise and control all the business and affairs of the Association, including the filing of liens for unpaid Assessments in accordance with the Declaration and the enforcement activities of the Association. He or she shall, when present, preside at all meetings of the Board. He or she may sign, with the Secretary, Treasurer or any other proper officer of the Association authorized by the Board, any deeds, mortgages, bonds, contracts, or other instruments which the Board has authorized to be executed, except in cases where the signing and execution thereof shall be expressly delegated by the Board or by the Declaration to some other officer or agent of the Association, or shall be required by law to be otherwise signed or executed, and in general shall perform all duties incident to the office of President and such other duties as may be prescribed by the Board from time to time.
- 5.6 **Secretary and Treasurer.** The Secretary and the Treasurer shall serve on the Board and perform such duties as may be directed by the President in conducting Association business. The Secretary shall preside over any meeting in the absence of the President, and shall perform such duties as may be specified and exercise such powers as may be delegated by the Board. The Secretary shall keep the minutes of the Board and Member meetings in one or more books provided for that purpose, see that all notices are duly given in accordance with the provisions of the Declaration and these Bylaws, be custodian of the Association records, regulations, rules and resolutions and of the seal of the Association, if any, and keep a register of the post office address of each Director which shall be furnished to the Secretary by each Director, and in general perform all duties incident to the office of Secretary and such other duties as from time to time may be assigned to him or her by the President or by the Directors. If required by the Board, the Treasurer shall give a bond for the faithful discharge of his or her duties in such sum and with such surety or sureties as the Board shall determine. He or she shall have charge and custody of and be responsible for all funds and securities of the Association, receive and give receipts for moneys due and payable to the Association from any source whatsoever, including Assessments, and deposit all such moneys in the name of the Association in such banks, trust companies or other depositories as shall be selected in accordance with the Declaration. The Treasurer shall be responsible for the collection of periodic Assessments to be collected. Further, the Treasurer shall record the Assessments due and paid and shall prepare quarterly reports reflecting the Association's assets, including the Assessments due and paid and shall mail or otherwise provide a copy of the quarterly reports to each Director. The Treasurer may, with the consent of the Board, retain an accountant or bookkeeper to assist with or perform such duties. In general, the Secretary and Treasurer shall perform all of the duties incident to the offices of Secretary and Treasurer and such other duties as from time to time may be assigned to him or her by the President or by the Directors.

- 5.7 **Salaries.** The salaries of the officers, if any, shall be fixed from time to time by the Board and no officer shall be prevented from receiving such salary by reason of the fact that he or she is also a Director.
- 5.8 **Other Duties, Obligations and Rights.** The officers shall have all the duties, obligations and rights specified in the Declaration as well as those specified herein.

ARTICLE 6 - CONTRACTS, LOANS, CHECKS AND DEPOSITS

- 6.1 **Contracts.** The Board may authorize any officer or officers, agent or agents of the Association to enter into any contract or execute and deliver any instrument in the name of and on behalf of the Association, and such authority may be general or confined to specific instances.
- 6.2 **Loans.** No loans shall be contracted on behalf of the Association and no evidence of indebtedness shall be issued in its name unless properly authorized by resolution of the Board. Such authority may be general or confined to specific instances.
- 6.3 **Checks, Drafts, etc.** All checks, drafts or other orders for the payment of money, notes or other evidences of indebtedness issued in the name of the Association shall be signed by such officer or officers, agent or agents of the Association and in such manner as shall from time to time be determined by resolution of the Board.
- 6.4 **Deposits.** All funds of the Association not otherwise employed shall be deposited from time to time to the credit of the Association in such banks, trust companies or other depositories as the Board may select.

ARTICLE 7 - MAINTENANCE

- 7.1 **Annual Resolution.** The Board shall adopt annually a resolution reflecting the current year plan and budget for repair, maintenance and operation of the Common Elements and other property for which the Association is responsible as provided in the Declaration, and to perform other functions of the Association. The President of the Association or the Manager, as determined by the Board, shall implement this plan and the Treasurer shall pay for the expenses from Association funds collected.
- 7.2 **Repairs, Maintenance and Operation.** Repairs, maintenance and operation of the Common Elements and other property for which the Association is responsible as provided in the Declaration shall be performed on an "as needed" basis and the President of the Association or the Manager, as determined by the Board, is authorized to initiate all repairs, maintenance and/or other operations which are estimated to be less than Ten Thousand Dollars and Zero Cents (\$10,000) in expense. All repairs, maintenance or other operations estimated as requiring Ten Thousand Dollars and Zero Cents (\$10,000) or more in expense shall be initiated by the President of the Association

or the Manager only after the Board has adopted a resolution specifically authorizing the expense, which may be authorized individually or in a budget for the Association. Expenses for repair, maintenance and operation shall be paid by the Treasurer of the Association from the Association funds received as Assessments or otherwise consistent with the Declaration. In order to implement maintenance or operation resolutions, the President or the Manager may employ any personnel reasonably necessary to properly effect said maintenance and repair.

ARTICLE 8 - BUDGET AND RECORDS

- 8.1 Budget.** The Board shall draft and approve an annual budget for each fiscal year. The budget may be amended by resolution of the Board. If no budget is adopted, the last existing budget shall continue until amended by the Board.
- 8.2 Records.** The Board shall keep detailed records of the actions of the Board, including minutes of the meetings of the Board and minutes of the meetings of the Members. The Board shall also keep detailed and accurate financial records in chronological order of the receipts and expenditures of common obligations or of individual obligations for which the Board is serving as the conduit for payment of expenses. The Board shall also maintain an Assessment roll in which there shall be an account for each Owner. Such account shall designate the name and address of the Owner, the amount of each Assessment, the dates and amounts on which the Assessment becomes due, the amounts paid upon the account and the balance due on the Assessment.
- 8.3 Inspection by Members.** The Members shall have the right to inspect and copy, at the Member's expense, at a reasonable time and location specified by the Association, any of the records of the Corporation specified in, and in compliance with, Mont. Code Ann. §§ 35-2-907 through 35-2-912. The Board may establish reasonable rules with respect to any such inspection, including rules regarding advance notice of an inspection and hours and days of the week when such an inspection may be made.

ARTICLE 9 - RULES AND REGULATIONS

The Board may adopt such Rules and Regulations regarding use and operation of the Common Elements as may be reasonably necessary, provided such Rules and Regulations are consistent with and are in compliance with the Declaration.

ARTICLE 10 - ASSESSMENTS

In compliance with the Declaration, the Board may authorize Assessments against the Units of Members.

ARTICLE 11 - AMENDMENT

These Bylaws may be amended only by the affirmative vote or written consent of seventy-five percent (75%) of the Members.

ARTICLE 12 - MISCELLANEOUS

- 12.1 Conflicts.** In the case of any conflict between the Articles and these Bylaws, the Articles shall control; and in the case of any conflict between the Declaration and these Bylaws, the Declaration shall control.
- 12.2 Fiscal Year.** The fiscal year of the Association shall begin on the 1st day of January of each calendar year and end on the 31st day of December of that same calendar year. The fiscal year may be changed by resolution of the Board.
- 12.3 Severability.** Whenever possible, each provision of these Bylaws will be interpreted in such manner as to be effective and valid to the fullest extent permitted by law. If any provision of these Bylaws is determined to be invalid, illegal or unenforceable, the validity, legality and enforceability of the remaining provisions of these Bylaws shall not be affected or impaired in any way.

IN WITNESS WHEREOF, we certify that these Bylaws for the Edge 7 Condominium Owner's Association Inc., was adopted by the Declarant, Dehaan Construction, Inc.

ATTEST:

Dehaan Construction, Inc.

[Handwritten signature of Darrel DeHaan]

By: Darrel DeHaan, President

STATE of Montana)

: ss.

County of Gallatin)

On this 5th day of November, 2020, before me, a Notary Public in and for said State, personally Darrel DeHaan, President of **Dehaan Construction, Inc.** and acknowledged to me that he executed the same on behalf of the Declarant limited liability company pursuant to the power and authority vested in him.

IN WITNESS WHEREOF, I have hereunto set my hand and affixed my Notarial seal the day and year written above.

[SEAL]

[Handwritten signature of Anthony Tyler Doshier]
Anthony Tyler Doshier, Notary Public

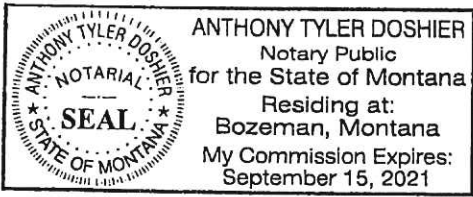

EXHIBIT A

Description of Property

The following described real property located in Gallatin County, Montana:

All that part of Block 15 of Belleview Addition to the Town of Belgrade, Montana, laying South of Custer Avenue or the extension of said Custer Avenue, according to the official plat of Belleview Addition to the Town of Belgrade, Montana, according to the official plat on file and of record in the office of the County Clerk and Recorder of Gallatin County, Montana. EXCEPTING THEREFROM 50 feet off the entire North end of all that part of Block 15 of the Belleview Addition to the Town of Belgrade, lying south of Custer Avenue or the extension of said Custer Avenue, according to the official plat of Belleview Addition to the Town of Belgrade, Montana, according to the official plat on file and of record in the office of the County Clerk and Recorder of Gallatin County, Montana. [Deed Reference: Film 9, page 1587]

TOGETHER WITH that portion of vacated Cascade Avenue located in Block 15 of Belleview Addition which attached to said lot by operation of law pursuant to Resolution No. 467 dated November 7, 1977 and recorded June 26, 1978 in Film 44, page 1006, records of Gallatin County, Montana.